

User guide

Motorhomes

EXTERNAL DIMENSIONS			
Model	Length (cm)	Width (cm)	Height (cm)
T 590	599	232	285
T 640	649	232	285
T 680	699	232	285
T 690	699	232	285
TE 740	748	232	285
TQ 740	748	232	285
A 595	599	232	314
A 690	699	232	314
A 720	720	232	314

 **WARNING**

The given dimensions are standard values defined during the approval procedure. Due to manufacturing tolerances, the actual dimensions may slightly differ from the given values. Deviations of up to $\pm 3\%$ of the dimensions are permitted and possible. The factory installation of optional equipment may influence the declared dimensions of the relevant model.

 **WARNING**

Please observe the chassis manufacturer's operating instructions at all times.

 **WARNING**

We recommend to download the updated version of the Renault manual at the following address:
<https://www.e-guide.renault.com/portail>





 **WARNING**

Never use a backward-facing child restraint system on a seat protected by an active frontal airbag. Risk of death or serious injury to the child.

 **NOTE**

This manual refers to devices and/or features that may be optional (not standard) or not foreseen for certain models.

 **WARNING**

The terms used in this manual with regard to weight specifications are explained again in detail at the end of the manual, in the chapter "Legal notes on weight-related information".

 **WARNING**

There may be magnets on the vehicle, for example for closing doors/hatches or for aligning sofa cushions. Magnets can affect the functioning of devices such as pacemakers and implanted defibrillators, with serious health risks. If you have one of these devices, keep a safe distance from the magnets. Warn any wearers of these devices not to get too close.

TABLE OF CONTENTS

1 - Safety..... 5	5 - Windows and roof lights23
1.1 General rules..... 5	5.1 Windows..... 23
1.2 Fire prevention 6	5.2 Cab windows..... 23
1.3 In case of fire..... 6	5.3 Roof lights 24
1.4 Regulations for supplying electricity..... 6	5.3.1 Dometic Micro/Mini/Midi Heki..... 24
1.4.1 During connection 6	5.3.2 MPK 40 X 40..... 25
1.4.2 During disconnection 6	5.3.3 MPK 28 X 28..... 25
1.4.3 Additional inspections 6	5.3.4 Polyplastic StarView..... 25
1.5 Technically permissible maximum laden mass 7	5.3.5 Vehicles with drop-down bed over the dinette (optional) 26
1.6 Actual weighed mass and remaining load capacity 7	
1.7 Technically permissible maximum laden mass on the axle (mass on the axle)..... 8	6 - Electrical system27
1.8 Increase of load capacity and reduction of load capacity 9	6.1 Introduction..... 27
1.9 Load distribution and load securing 10	6.2 12 V distribution control unit - Fuses..... 27
1.10 Rear garages and rear storage compartments (depending on the model) 11	6.3 Control panel 28
1.11 Refuelling 12	6.4 Batteries..... 28
1.12 Removable inside ladder 13	6.4.1 Engine battery 28
1.13 Inside steps..... 13	6.4.2 Auxiliary battery..... 28
1.14 Furniture doors 13	6.5 Power supply - Battery charger..... 30
1.15 Cab blinds..... 13	6.6 Booster 31
1.16 Cab carpeting..... 13	6.7 Other components..... 32
1.17 Magnets..... 14	
1.18 Front passenger side airbag and child restraint systems..... 14	7 - Refrigerator33
1.19 Headrest..... 14	7.1 Warning..... 33
	7.2 LED control panel..... 33
2 - General advice..... 15	7.3 LCD touchscreen..... 34
2.1 Warning..... 15	7.4 Manual selection of the type of power supply 34
2.2 Departure..... 15	7.5 Automatic mode 34
2.3 Driving 15	
2.4 Stops..... 16	8 - Gas system35
	8.1 General description 35
3 - Seatbelts 17	8.2 Gas pressure regulator with crash sensor (optional) 35
3.1 Use and maintenance..... 17	8.3 Gas bottle replacement..... 36
3.1.1 How to use the seatbelts..... 17	8.4 Hob and oven..... 37
3.1.2 Maintenance and cleaning of the belts..... 18	
3.2 Vehicles equipped with Isofix attachment for transporting children (optional) 18	9 - Heating system..... 39
3.2.1 T 640, T680, TE 740, TQ 740 18	9.1 Truma heating system..... 39
3.2.2 A 720 19	9.2 Control panel 39
3.2.3 T 690, A 690..... 19	9.3 Drain valve..... 40
3.2.4 Isofix..... 20	9.4 Electric floor warming unit (optional)..... 40
4 - Doors..... 21	10 - Water system 41
4.1 Key equipment 21	10.1 Introduction..... 41
4.1.1 Remote control integrated in the ignition key 21	10.2 Fresh water tank 41
4.2 Living quarters door 22	10.3 Waste water tank..... 42
4.2.1 Internal door locking 22	
	11 - Washroom 43
	11.1 Cassette-type toilet..... 43
	11.2 Shower cab (T 690, A 690)..... 44
	11.3 Shower cab (T 590) 45

12 -	Internal components	47
12.1	Table - A type	47
12.2	Table - B type	47
12.3	Table - C type	47
12.4	Tables with telescopic leg (A type).....	48
12.5	Tables with telescopic leg (B type).....	48
12.6	Beds with electric handling (optional)	48
12.6.1	Bed above the dinette	48
12.6.2	Rear bed.....	49
12.7	Other components.....	49
12.7.1	Bed safety net.....	49
12.7.2	Cab seating.....	50
13 -	Settees	51
13.1	Lengthways settee.....	51
13.2	"L"-shaped settee	52
14 -	Night conversion (optional)....	53
14.1	T 640, T 680, TE 740, TQ 740	53
14.2	T 690, A 690.....	54
14.3	A 720	54
14.4	T590, A595.....	55
15 -	Accessories	57
15.1	Safety	57
16 -	Maintenance.....	59
16.1	Tyres	59
16.1.1	General warnings.....	59
16.1.2	Tyre pressure.....	59
16.2	Cleaning.....	60
16.2.1	Interior	60
16.2.2	Upholstery	60
16.2.3	Exterior	60
16.2.4	Tanks.....	60
16.3	Flooring.....	61
16.4	Furniture	61
16.5	Headlights	61
16.6	Inactivity of the vehicle	62
16.6.1	In case of danger of frost.....	62
16.6.2	Before a long period of inactivity.....	62
16.6.3	After a long period of inactivity	62
16.7	Renault chassis number	63
16.8	Customer service.....	63
16.8.1	Spare parts and accessories.....	63
17 -	Legal notes on weight-related information.....	65
17.1	Technically permissible maximum laden mass.....	65
17.2	Mass in running order.....	65
17.3	Mass of the passengers.....	65
17.4	Optional equipment and actual mass of the vehicle.....	65
17.5	Pay-mass and minimum pay-mass.....	66
17.6	Effects of tolerances of the mass in running order on the pay-mass.....	67

1.1 General rules

- Read this handbook before using the motorhome for the first time.
- Follow all the instructions on labels inside the vehicle
- Using the vehicle in faulty conditions is dangerous for passengers and things as well as for the vehicle itself.
- Do not carry inside the vehicle material that can cause dangerous fumes.
- The water from the tanks is not suitable for drinking, cooking or washing food.
- The kitchen sink cover and any other free object that could be dangerous during the journey must be kept in closed places.



WARNING

Never leave children alone inside the vehicle.



WARNING

Qualified personnel only can carry out maintenance operations of both gas and electrical systems.



WARNING

Inspect flexible gas hoses regularly for deterioration and renew as necessary with the approved type. Either the expiry date or the production date is marked on the hoses. If the production date is indicated, refer to the regulations in force in your country to determine the expiry date. In any case, the expiry date of the hoses may vary depending on the country you are in.



WARNING

The beds should only be used if mattresses are present. Access to beds without mattresses jeopardizes the structure of the bed itself and the integrity of the slatted base.



WARNING

Use upper bunks for sleeping only, with protection against falling-out. Care should be taken against the risk of falling out when upper bunks are used by children, especially under 6 years of age. These bunks are not suitable for use by infants without supervision.



WARNING

Your vehicle is equipped with a refrigerator specifically designed for caravans, motorhomes and nautical vehicles that can operate with three different sources of energy: 230 V, 12 V and gas. We recommend the utmost care in storing perishable food because the performances of this appliance cannot be compared with those of a household refrigerator constantly powered at 230 V and they are also affected by the climatic conditions the vehicle is exposed to.



WARNING

If you have purchased a new vehicle, please get the wheel bolts checked by a specialised workshop after traveling 50 km.



WARNING

In case the vehicle is being transported on other means of transportation (for example trains, ferries, emergency vehicles, etc.) the vehicle must be positioned so as to travel facing forwards, in the travel-direction.

1.2 Fire prevention

- Provide one dry powder fire extinguisher complying with EN 3-7 of at least 1 kg capacity, or one equivalent fire extinguisher, by the main exit door, and a fire blanket next to the cooker. Familiarise yourself with the instructions on your fire extinguisher and the local fire precaution arrangements.



WARNING

Inside the vehicle never use any kind of braziers, portable equipments for heating or cooking, as there is a risk of fire and death by asphyxiation.



WARNING

It is forbidden to transport easily inflammable materials (petrol, diesel oil, kerosene oil, propane gas, butane gas, natural gas, ect.) inside the vehicle. Keep combustible materials (wood, fabric, cotton, wool, board, ect.) far from heating system and burners. Gas bottles must be transported exclusively inside the special locker. During the journey or during stops at filling stations it is forbidden to keep the main valve of the gas bottle open.



WARNING

If you transport mopeds or similar, which are powered by flammable fuels, make sure that their tank is completely empty.

1.3 In case of fire

- Evacuate the passengers and call the firemen.
- Close the gas bottle valve and try to extinguish the flames (only in case these operations are not dangerous).

1.4 Regulations for supplying electricity

1.4.1 During connection

- 1) Before connecting the motorhome system to the electricity supply, check that:
 - the power supply system provided at the campsite has suitable voltage for the motorhome's electrical system and electric appliances;
 - the cable and connections are all compatible;
 - the motorhome's circuit breaker (see electrical system chapter in this manual) is turned to the "OFF" position.



WARNING

The power supply cable must be fully unwound to prevent any damage from overheating.

- 2) Check that the cable, connectors and connections are all intact and not damaged in any way.
- 3) Take the cover off the external 230 V socket and insert the plug.
- 4) Connect the cable to the socket of the campsite power point.
- 5) Turn the motorhome's circuit breaker to the "ON" position.
- 6) Check that the motorhome's circuit breaker operates correctly by pressing the test button, and then reactivating it again.

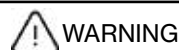

WARNING

In case of doubt or if the power supply fails to work or malfunctions after being connected, contact the manager of the campsite.

1.4.2 During disconnection

Turn motorhome's circuit breaker on the "OFF" position and first disconnect the power supply cable from the camping site mains, and then from the motorhome's system.

1.4.3 Additional inspections

It is recommended to have the motorhome's power supply system inspected at least once every three years - and once a year in case of intensive use of the vehicle - by a qualified electrician who can provide a printed report of the system's actual conditions.

1.5 Technically permissible maximum laden mass

The technically permissible maximum laden mass is a value specified by the manufacturer that, for safety reasons, the vehicle must never exceed, even when loaded (e.g. 3,500 kg). Information on the technically permissible maximum laden mass can be found in the registration papers and on the body manufacturer's nameplate in the vehicle, behind the right cab seat.

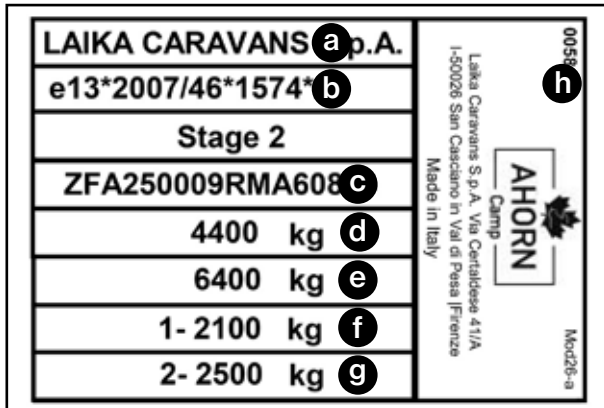

Example of body manufacturer's nameplate

- a) Manufacturer name.
- b) Type-approval number.
- c) Chassis number.
- d) Technically permissible maximum laden mass.
- e) Technically permissible maximum laden mass of vehicle plus trailer combination.
- f) Technically permissible maximum laden mass on the front axle.
- g) Technically permissible maximum laden mass on the rear axle.
- h) Ahorn Camp chassis number.

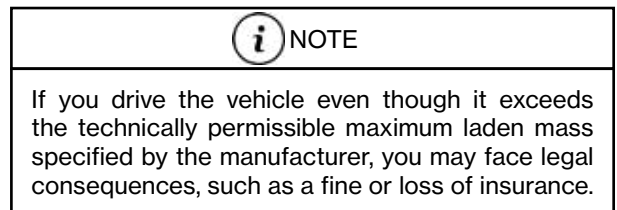
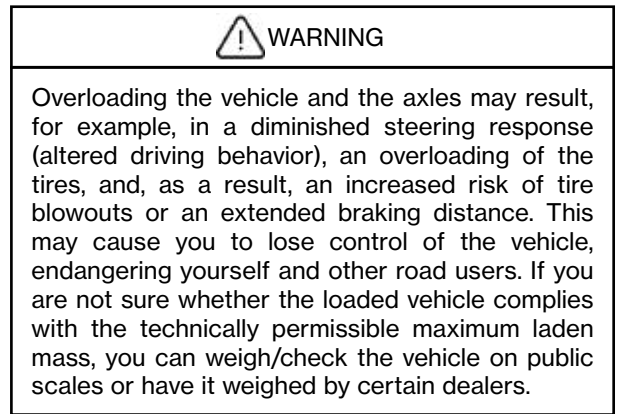
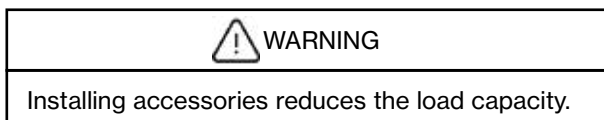
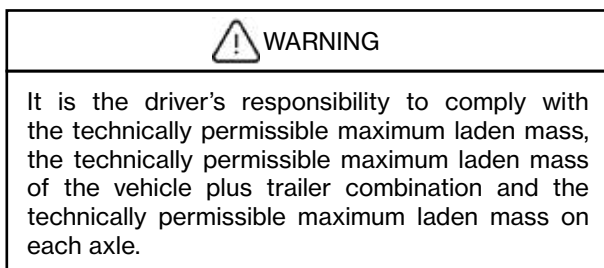

1.6 Actual weighed mass and remaining load capacity

To determine the remaining load capacity, it is important that you know the actual weighed mass of your vehicle.

Upon completion of your vehicle, therefore, we determine the actual weight of your vehicle for the first time by weighing it at the end of the line. This includes the mass in running order plus the weight of all ordered and factory-fitted optional equipment.

You can use this actual weighed mass to calculate the remaining load capacity for baggage or other accessories. Example:

Technically permissible maximum laden mass	Actual weighed mass	Mass of passengers	Remaining load capacity
3500 kg	- 3000 kg	- 225 kg (3 * 75 kg)	= 275 kg

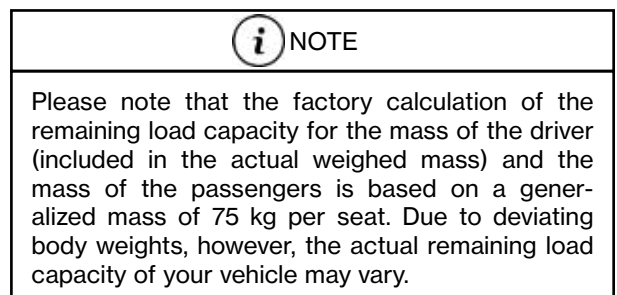

i NOTE

The actual factory-weighed mass of your vehicle may vary slightly afterwards due to weather conditions and, for example, the associated absorption or release of moisture. Any further subsequent modification of your vehicle, e.g. through the additional installation of accessories by the dealer or other attachments and/or conversions, will additionally influence the actual weighed mass of the vehicle communicated and consequently also the remaining load capacity. It is the responsibility of the dealer after picking up the vehicle at the factory until delivery, and subsequently your responsibility from the time of handover by the dealer, to ensure that the technically permissible maximum laden mass is not exceeded. If you are not sure whether the loaded vehicle complies with the technically permissible maximum laden mass, you can weigh/check the vehicle on public scales or have it weighed by certain dealers.

i NOTE

We will inform your dealer of the actual weighed mass of your vehicle and the remaining load capacity when we issue the invoice. Your dealer is required to pass on the information to you. If you have not received this information, you can contact your dealer and request it. Our scales meet all legal and standard requirements and are regularly maintained, tested and, calibrated. Nevertheless, a slight tolerance is technically unavoidable. Moreover, the weight of the vehicle may vary slightly due to weather conditions and, for example, the associated absorption or release of moisture. The actual weight of the vehicle may therefore deviate from the actual weight communicated by a few kilograms.

1.7 Technically permissible maximum laden mass on the axle (mass on the axle)

The technically permissible maximum laden mass on the axle or group of axles (hereafter referred to as mass on the axle) refers to the vehicle- and axle-specific load that may be transferred from the wheels of an axle or group of axles to the road surface. The mass on the axle is a value specified by the manufacturer that, for safety reasons, the vehicle must never exceed, even when loaded.

You will find information on the mass on the axle of your vehicle in the registration papers and on the body manufacturer's nameplate in the vehicle, behind the right cab seat.

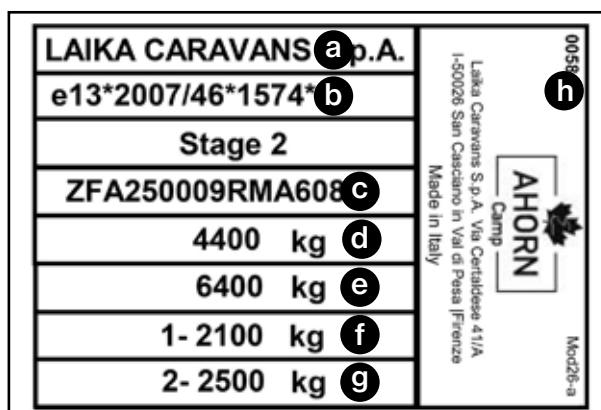

Example of body manufacturer's nameplate

- a) Manufacturer name.
- b) Type-approval number.
- c) Chassis number.
- d) Technically permissible maximum laden mass.
- e) Technically permissible maximum laden mass of vehicle plus trailer combination.
- f) Technically permissible maximum laden mass on the front axle.
- g) Technically permissible maximum laden mass on the rear axle.
- h) Ahorn Camp chassis number.

**WARNING**

If the technically permissible maximum laden mass on the axle is exceeded, the vehicle may be damaged (e.g. due to a broken axle or tire blowout) and driving performance may be considerably impaired. This may cause you to lose control of the vehicle, endangering yourself and other road users. We therefore recommend weighing the final loaded vehicle including all passengers before commencing travel in order to ensure compliance with the mass on the axle and the technically permissible maximum laden mass at all times. For this purpose, you can weigh/check the vehicle on public scales or have it weighed by certain dealers.

**NOTE**

Please note that the mass on the respective axles or axle groups may differ. For this reason, please read the information provided in the registration papers carefully.

**NOTE**

If you drive the vehicle even though it exceeds the technically permissible maximum laden mass on the axle specified by the manufacturer, you may face legal consequences, such as a fine or loss of insurance.

**NOTE**

It is possible that the chassis manufacturer of your vehicle specifies a minimum load for the front axle in order to achieve optimum driving behavior. Therefore, please also always observe the information regarding this from the operating instructions of the chassis manufacturer.

**NOTE**

For further information on correct loading, please refer to the paragraphs 1.9 "Load distribution and load securing" and 1.10 "Rear storage spaces and rear garages".

1.8 Increase of load capacity and reduction of load capacity

In the case of an increase of load capacity, a change in the chassis usually increases the technically permissible maximum laden mass of the vehicle, the technically permissible maximum laden mass on the axle and, as a result, the remaining load capacity for luggage, camping equipment, etc.

In contrast to an increase of load capacity, a reduction of load capacity reduces the technically permissible maximum laden mass of the vehicle, the technically permissible maximum laden mass on the axle and, as a result, the remaining load capacity for luggage, camping equipment, etc. As a rule, a technical modification of the chassis is not performed.

**NOTE**

Due to the change in the technically permissible maximum laden mass, increases or reductions of load capacity may affect the permitted seats, the chassis, and the mass on the axle. If you have any questions, feel free to contact the responsible technical testing center for advice.

**NOTE**

A reduction or increase of load capacity may result in changes to the legal requirements resulting from the new technically permissible maximum laden mass of the vehicle. This applies in particular to the legal requirements from the German Road Traffic Act (StVO), the German Road Vehicle Registration Regulation (StVZO), and tax and insurance regulations. An increase of technically permissible maximum laden mass to over 3,500 kg may, for example, affect the driving license class or result in different speed limits or prohibitions on passing and overtaking. Toll payment requirements may also change due to the new technically permissible maximum laden mass. Therefore, inform yourself about the current legal situation with regard to the new technically permissible maximum laden mass of the vehicle and seek advice on this from the appropriate bodies. Please note that national regulations in the country of your destination and countries visited in transit may differ from those in your home country.

**NOTE**

For more information on the actual weighed mass of your vehicle and the remaining load capacity, please refer to the paragraph 1.6 "Actual weighed mass and remaining load capacity".

1.9 Load distribution and load securing

When loading the vehicle, please observe the following instructions to ensure safe driving:

- Baggage and other items carried in the vehicle must be evenly distributed between the left and right sides of the vehicle.
- Heavy or bulky items should be stowed as close to the ground as possible in stowage boxes provided for this purpose and near the axles, and they must be secured against slipping.
- Light and other items can be stowed in lockers and storage compartments.
- Always ensure that the doors and flaps on the cabinets and storage compartments are properly secured.
- Use only suitable clamping systems to secure items against slipping. Please recheck all tie-downs before commencing travel.

WARNING

Uneven loading has a negative effect on driving behavior. A rear-heavy load in particular results in a reduction of the load on the front axle due to leverage effects and thus, for example, to a loss of traction, a diminished steering response (altered driving behavior), an overloading of the tires and, as a result, an increased risk of tire blowouts. This may cause you to lose control of the vehicle, endangering yourself and other road users. An evenly distributed load over the entire vehicle leads to optimum driving behavior during travel.

NOTE

The technically permissible maximum laden mass and the technically permissible maximum laden mass on the axle must not be exceeded. Especially when stowing or attaching heavy accessories or heavily laden accessories (such as motorcycle carriers or bicycle carriers) at the rear, the mass on the axle must be checked and complied with. If you are not sure whether the loaded vehicle complies with the technically permissible maximum laden mass and the technically permissible maximum laden mass on the axle, you can weigh/check the vehicle on public scales or have it weighed by certain dealers.

NOTE

The technically permissible maximum laden mass and the technically permissible maximum laden mass on the axle must not be exceeded. Especially when stowing or attaching heavy accessories or heavily laden accessories (such as motorcycle carriers or bicycle carriers) at the rear, the mass on the axle must be checked and complied with. If you are not sure whether the loaded vehicle complies with the technically permissible maximum laden mass and the technically permissible maximum laden mass on the axle, you can weigh/check the vehicle on public scales or have it weighed by certain dealers.

WARNING

Limit the load of each individual wall-fitted cupboard (upper cabinet) to a max. of 5 kg.

NOTE

Further information on correct loading can be found in the paragraphs 1.5 “Technically permissible maximum laden mass”, 1.7 “Technically permissible maximum laden mass on the axle (mass on the axle)” and 1.10 “Rear garages and rear storage compartments”.

1.10 Rear garages and rear storage compartments (depending on the model)

When loading rear garages and rear storage compartments, please observe the following instructions to ensure safe driving:

- Baggage and items carried in rear garages and rear storage compartments must also be evenly distributed in accordance with the paragraph 1.9 "Load distribution and load securing".
- All items stowed in rear garages and rear storage compartments must be fastened and secured accordingly using suitable clamping systems at the existing fastening points provided at the factory.
- Before driving off, it must be ensured that the rear garage or rear storage compartment is properly locked.

WARNING

Uneven loading or overloading has a negative effect on driving behavior. A rear-heavy load in particular results in a reduction of the load on the front axle due to leverage effects and thus, for example, to a loss of traction, a diminished steering response (altered driving behavior), an overloading of the tires and, as a result, an increased risk of tire blowouts. This may cause you to lose control of the vehicle, endangering yourself and other road users. An evenly distributed load over the entire vehicle leads to optimum driving behavior during travel. If you are not sure whether the loaded vehicle complies with the technically permissible maximum laden mass and the technically permissible maximum laden mass on the axle you can weigh/check the vehicle on public scales or have it weighed by certain dealers.

WARNING

When transporting vehicles powered by gasoline, diesel, gas, or other flammable material, make sure that the tank of the transported vehicle is completely empty. When transporting electric bikes, we also recommend that you remove and securely stow the battery before commencing travel.

WARNING

Rear garages and rear storage compartments are not designed at the factory to function as sleeping or living areas for people or animals. These spaces are not provided with ventilation at the factory. There is a risk of suffocation due to a lack of oxygen.

WARNING

Distribute the load evenly. Loads concentrated too much in one place can damage the floor covering.

WARNING

The maximum permissible load of the rear garage or rear storage compartment is 150 kg.

NOTE

Please observe the maximum permissible load of the rear garage or rear storage compartment at all times. The specified maximum permissible load of the rear garage or rear storage compartment may be influenced by the selection of further optional equipment, such as trailer couplings or frame extensions. However, the technically permissible maximum laden mass and the technically permissible maximum laden mass on the axle must not be exceeded under any circumstances. Especially when stowing or attaching heavy accessories or heavily laden accessories (such as motorcycle carriers or bicycle carriers) at the rear, the mass on the axle must be checked and complied with. For this reason, please note that the maximum load may not be fully utilized if this would result in the exceedance of the technically permissible maximum laden mass or technically permissible maximum laden mass on the axle.

NOTE

Further information on correct loading can be found in the paragraphs 1.5 "Technically permissible maximum laden mass", 1.7 "Technically permissible maximum laden mass on the axle (mass on the axle)" and 1.9 "Load distribution and load securing".

1.11 Refuelling

The refuelling cap is located on the exterior left wall of the vehicle near the driving cab and is marked with "DIESEL".



! WARNING

Other caps for water tank refilling may also be present on the exterior vehicle wall. Use the utmost care to avoid confusing the two types of caps.



! WARNING

Close the main valve of the gas bottle before refuelling.

! WARNING

During the journey or during stops at filling stations it is forbidden to keep the main valve of the gas bottle open.

Additive for diesel emissions AdBlue®

The vehicle is equipped with a system to reduce harmful emissions. This system requires a regular supply of an additive (AdBlue®).

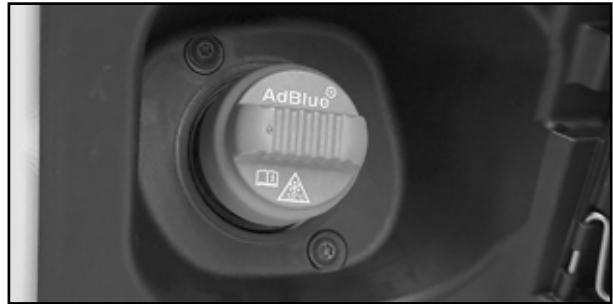

Renault chassis

The cap, in light blue color, for the supply of the additive is located in different places according to the various models:

- Models on Renault chassis: outer door on the left side, together with the diesel filler.

! WARNING

Other caps for water tank refilling may also be present on the exterior vehicle wall. Use the utmost care to avoid confusing the two types of caps.

! WARNING

For warnings relating to the operation of the emissions reduction system and the refuelling methods for the AdBlue® additive, refer to the chassis manual.

1.12 Removable inside ladder

Some models can be equipped with a removable ladder that gives access to the raised beds.

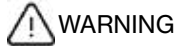

WARNING

Make sure the ladder is not damaged before using it to climb into or out of bed. The ladder must be securely fastened to the corresponding hooks on the bed and should rest on the floor in a stable manner.



WARNING

There is a risk of falling when using the ladder: be careful when climbing into or out of bed.



WARNING

The ladder has been designed for climbing into and out of bed inside the vehicle. Do not use the ladder for other purposes.

1.13 Inside steps

Some vehicles are equipped with steps that connect different areas of the living area or facilitate access to the raised beds.



WARNING

Memorise the position of inside steps so as not to accidentally walk into or trip on them: doing so can cause a risk of falling and injury.

1.14 Furniture doors

Some furniture doors, either high or low, may remain open in positions in which they may strike vehicle users, e.g. high doors may interfere with the head and low doors may interfere with the legs. Use extreme caution to avoid injury.

1.15 Cab blinds

If the vehicle is fitted with cab blinds for the windscreen and side windows, before driving whilst the vehicle is stationary please check that all blinds are fully open and are locked by the relevant catches. Pay particular attention to the windscreen blind. It is in two halves and must be securely fastened to the side catches. After locking the blinds with the catches, try to unlock them by pulling them quite strongly but without releasing the catches: the blinds must remain locked.



WARNING

If these procedures are not followed, there is a risk that the blinds will close inadvertently while driving, causing accidents, which can have very serious consequences.



WARNING

If you are not sure of the integrity of the blind locking mechanisms, do not drive the vehicle and contact an Ahorn Camp authorised workshop.

1.16 Cab carpeting

Ensure that any carpet located in the cabin is always laid flat and does not interfere with the driver's pedals.



WARNING

Before each departure ensure that any carpet does not interfere with the driver's pedals.

1.17 Magnets

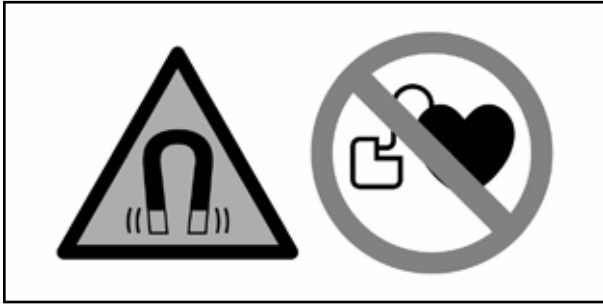

WARNING

There may be magnets on the vehicle, for example for closing doors/hatches or for aligning sofa cushions. Magnets can affect the functioning of devices such as pacemakers and implanted defibrillators, with serious health risks. If you have one of these devices, keep a safe distance from the magnets. Warn any wearers of these devices not to get too close.

1.18 Front passenger side airbag and child restraint systems



WARNING

Never use a backward-facing child restraint system on a seat protected by an active frontal airbag. Risk of death or serious injury to the child.

1.19 Headrest

NOTE

The following instructions refer to the living area seats. For the seats into the cabin please refer to the chassis manual.

WARNING

Do not use a seat during the journey, without placing the headrest in an use position.

WARNING

The seat cannot be used while driving with the headrest completely lowered.



Position the upper part of the headrest at the same height as the top of the head, or the closest measurement, using the clicks provided in the headrest adjustment stroke.

WARNING

Adjust the headrest with the vehicle stationary before setting off.

WARNING

Do not adjust the headrest while the vehicle is in motion.

For satisfactory and continuous maintenance, you are recommended to follow the directions given herein and those contained in the Instructions for Use and Maintenance concerning the different appliances with which the recreational vehicle is fitted. Ahorn Camp vehicles are fitted on chassis made by various manufacturers. The accessories and components used are produced by a number of selected suppliers. The chassis manufacturers and producers of accessories and components run their service networks independently. Therefore, in case of need, it is recommended to directly contact the Service Dept. of the manufacturer of the faulty component. Having the recommended checks and services carried out, vehicle conditions will be optimised for many years.

2.1 Warning

In order to prevent any abnormal wear of tyres, we recommend that you check the toe-in values of your vehicle after driving the first 500 km. This should be done by a specialised workshop and at your charge. Should this check not be performed, Ahorn Camp shall not be held responsible for any inconvenience or damage resulting therefrom.

2.2 Departure

Before starting-off you are recommended to:

- remove any parking rests and smooth the ground around the vehicle, if the original conditions prior to your stay have been altered;
- make sure you have not forgotten anything under the vehicle or in the immediate vicinity;
- turn off the 230 V connection;
- close the gas bottle valve;
- firmly position all items inside the vehicle;
- make sure that all internal doors and cabinet doors are closed;
- make sure that all the windows are closed;
- close the roof-lights;
- take a look at the control panel in order to check the level of the fresh water tank and of the different waste water tanks, as well as the condition of the battery;
- make sure that cab and entrance doors are closed;
- correctly direct the side mirrors;
- if possible, remove or move away the table in front of the rear seats;
- make sure that all passengers are seated as required for driving;
- fasten your seat belts.

WARNING

Before departure it is mandatory to completely empty the hot water boiler.

WARNING

It is required before departure to empty the fresh water tank down to 20 litres. This can be done by using the dedicated discharge tap.

2.3 Driving

No matter how easy it is to drive a recreational vehicle, it is necessary to remember that you are at the wheel of a vehicle that is much more cumbersome than a car. The bigger size also involves more care at both the right hand side (do not drive too near to the guard rail) and the left hand side (do not stay in the middle of the road). It is advisable to practice a little to familiarise yourself with the new size. In particular, we suggest paying attention to the following:

- in case of wind, especially when overtaking, on viaducts or coming out of tunnels;
- before going under passages restricted in height, remember that accessories/optional equipment or baggage may be installed on the roof which increase the total height of the vehicle. Therefore, take care in: car parks which limit vehicle access in height, tunnels, garages and workshops, fuel station structures, tree branches, etc.;
- when reversing, take a careful look at the rear area and, if necessary, ask for the guidance of another person;
- going down very steep hills.

In general, and under all circumstances, especially when overtaking, remember that the performance levels of a recreational vehicle are unlikely to match those of your car. It is therefore necessary to strictly adhere to traffic regulations, particularly the safety distance.

2.4 Stops

During stops we advise you to:

- closely adhere to the various recommendations for use of the systems of the living quarters provided for in this handbook and in the instructions of the different appliances (refrigerator, boiler, oven, etc.), making sure these documents are on-board. Should any documentation be missing when the vehicle is handed over, it will be possible to ask Ahorn Camp's sales organisation for it;
- make sure that the vehicle is perfectly horizontal to ensure optimum performance of the various parts and systems;
- always find out about any local law concerning parking and camping.



Never obstruct the air inlets of the vehicle, both on roof and on floor level.



In case of long stops, the blinds of the bathroom window and of the bathroom roof-light must be kept closed.



The seats in the living area used by passengers while the vehicle is in motion are marked by the symbol displayed here on the side.

! WARNING

The driver of the motorhome bears full responsibility, both for him/herself and for the passengers, for the correct use of the seatbelts, as per the current local laws.

! WARNING

The reeling system blocks the seatbelt should it be taken out quickly, with an excessive pulling angle, and consequently with strong accelerations and/or decelerations. In order to pull it out you must let it briefly rewind in its holder and then pull it out again.

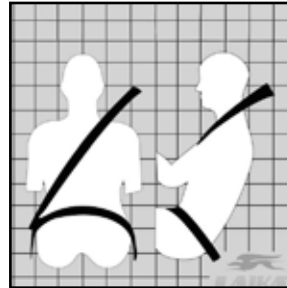

Picture 1 - 3 point seatbelt

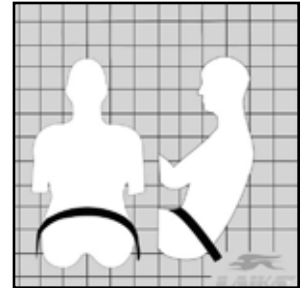

Picture 2 - Lap seatbelt

3.1 Use and maintenance

3.1.1 How to use the seatbelts

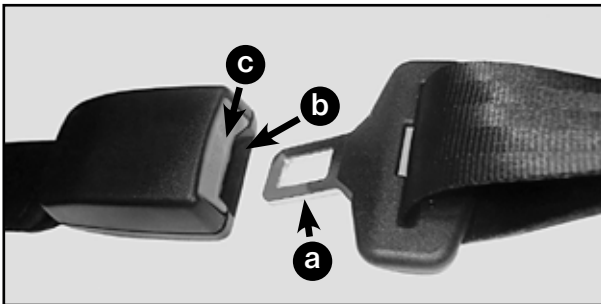

To fasten the seatbelt

- Grasp the metallic tab (a) of the seatbelt placed to your right, pass it around your abdomen and insert it in the buckle (b), placed to your left, until it is securely fastened inside.
- The seatbelt, once fastened, must be taut, placed tightly over the body, but it should not hinder the occupant's movements.
- You must be in an upright position and lean against the back of the seat while putting your seatbelt on.

To unfasten the seatbelt

- Press the red button (c) on the buckle, and accompany the seatbelt while it winds back into its holder (if it comes with a reeling system), so as to prevent it from twisting.

✓ THINGS TO DO

- Always put your seatbelt on before you get on the road.
- Follow the examples shown in pictures 1 and 2 in order to correctly put your seatbelt on.
- The seatbelts must be used on only one passenger at a time.
- Once you have arrived to your destination unfasten the seatbelt and slowly accompany it until it is completely wound up in its holder. Pay careful attention that it does not twist.

✗ THINGS TO AVOID

- Do not press the button (c) while the vehicle is in motion.
- The seatbelt must not be twisted in any way or part.
- Do not use devices that may hinder contact between the seatbelt and the passenger, or that may prevent the seatbelt from winding back into place.
- Do not hold children on your knees by using only one seatbelt to protect yourself and them.

! WARNING

The seatbelts described above were made for adult passengers with a minimum height of 150 cm.

3.1.2 Maintenance and cleaning of the belts

- Always make sure that the belts are not twisted in any way so that they may smoothly slide in and out.
- Wash the belts with water and neutral soap, then rinse. Let them dry at room temperature.
- Do not use any other types of detergents since they could ruin or weaken the texture of the belts.
- Do not wet the reels.
- Replace the belts should they be ripped and/or loose. This repair must be carried out by authorised personnel.

	THINGS TO DO
<ul style="list-style-type: none"> • If the seatbelt was used under great stress (such as in a serious accident), you must replace the entire system along with all its fastening equipment. 	

	THINGS TO AVOID
<ul style="list-style-type: none"> • Do not attempt to disassemble or alter the parts of the seatbelt. Each and every intervention must be carried out by authorised personnel. 	

3.2 Vehicles equipped with Isofix attachment for transporting children (optional)

In order to travel in a motorhome each passenger must be able to fasten him/herself to a suitable restraint system.

Also children must be fastened to restraint systems that are suitable for their weight / height / age, as stated in European Regulation ECE R44, since these systems are mandatory.

Child restraint systems are divided into 5 groups:

- Group 0 up to 10 kg
- Group 0+ up to 13 kg
- Group 1 9 – 18 Kg
- Group 2 15 – 25 Kg
- Group 3 22 – 36 Kg

3.2.1 T 640, T680, TE 740, TQ 740

The following child restraint systems may be placed on the seats of the motorhome:

Group	First row Passenger seat	Second row Seat position 3	Second row Seat position 4
0	See Renault manual	Not applicable	U E-ISO/R1
0+	See Renault manual	Not applicable	U E-ISO/R1
1	See Renault manual	Not applicable	U B-ISO/F2 B1-ISO/F2X A-ISO/F3
2	See Renault manual	Not applicable	Not applicable
3	See Renault manual	Not applicable	Not applicable

U = suitable for ISOFIX child restraint systems of universal category for the respective weight class.

	WARNING
Seat position 4 is only suitable for ISOFIX child restraint systems.	

	WARNING
The ISOFIX attachments of the vehicle are not suitable for ISOFIX D-ISO/R2-R2X, C-ISO/R3, F-ISO/L1 and G-ISO/L2 child restraint systems.	

	WARNING
Always check the correct attachment of the child seat, try to remove it without intervening with the locking device.	

3.2.2 A 720

The following child restraint systems may be placed on the seats of the motorhome:

Group	First row Passenger seat	Second row Seat position 5 and 6	Third row Seat position 3 and 4 (forward facing)
0	See Renault manual	Not applicable	U [E-ISO/R1]
0+	See Renault manual	Not applicable	U [E-ISO/R1] U [D-ISO/R2] U [C-ISO/R3]
1	See Renault manual	Not applicable	U [D-ISO/R2] U [C-ISO/R3] U [B-ISO/F2] U [B1-ISO/F2X] U [A-ISO/F3]
2	See Renault manual	Not applicable	U [Not applicable]
3	See Renault manual	Not applicable	U [Not applicable]

U = suitable for child restraint systems and for [ISOFIX child restraint systems] of universal category for the respective weight class.

 WARNING
The use of the child restraint system and the [ISOFIX child restraint system] is only permitted after the table has been removed.

 WARNING
The ISOFIX attachments of the vehicle are not suitable for ISOFIX F-ISO/L1 and G-ISO/L2 child restraint systems.

 WARNING
Always check the correct attachment of the child seat, try to remove it without intervening with the locking device.

3.2.3 T 690, A 690

The following child restraint systems may be placed on the seats of the motorhome:

Group	First row Passenger seat	Second row Seat position 5	Third row Seat position 3 and 4 (forward facing)
0	See Renault manual	Not applicable	U [E-ISO/R1]
0+	See Renault manual	Not applicable	U [E-ISO/R1] U [D-ISO/R2] U [C-ISO/R3]
1	See Renault manual	Not applicable	U [D-ISO/R2] U [C-ISO/R3] U [B-ISO/F2] U [B1-ISO/F2X] U [A-ISO/F3]
2	See Renault manual	Not applicable	U [Not applicable]
3	See Renault manual	Not applicable	U [Not applicable]

U = suitable for child restraint systems and for [ISOFIX child restraint systems] of universal category for the respective weight class.

 WARNING
The use of the child restraint system and the [ISOFIX child restraint system] is only permitted after lowering the table under the seat height. When the table is lowered, seats 3 and 4 cannot be used by adult passengers.

 WARNING
The ISOFIX attachments of the vehicle are not suitable for ISOFIX F-ISO/L1 and G-ISO/L2 child restraint systems.

 WARNING
Always check the correct attachment of the child seat, try to remove it without intervening with the locking device.

3.2.4 Isofix

Isofix-suitable car seats are provided with the Isofix symbol (2). The position of the top tether is marked with a symbol (3), too.

Fitting

- Connect the connectors (8) to retaining brackets (4) such that they are firmly engaged. While doing this, a distinctive click must be heard.
- With a strong jerk, check if the child seat (7) is firmly connected.
- Route top tether strap (5) over the headrest of the vehicle seat.
- Hook fixing hook (6) in at the top tether (1).

The removal is carried out analogously in inverted order.

4.1 Key equipment

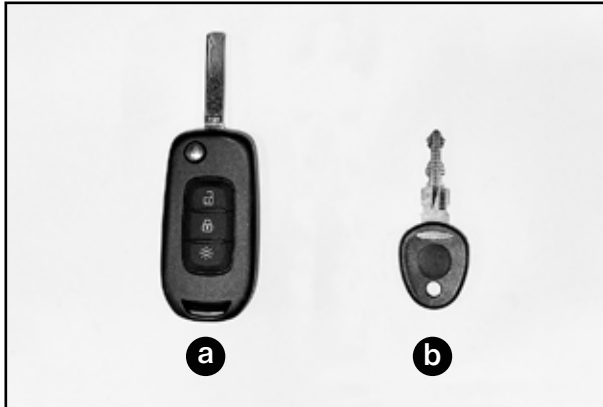

a) Key of the chassis.

b) Key of the living quarters door, storage hatches and water caps.

	THINGS TO DO
<ul style="list-style-type: none"> • Should the vehicle stay unwatched we advise you to always close it with a key. • Before any start please check that every single door has been closed properly. 	

	WARNING
<p>Some vehicles are equipped with a device called "deadlocking", which, if set, prevents the opening of the cab doors from inside. For information on this device, refer to the chassis manual.</p>	

4.1.1 Remote control integrated in the ignition key

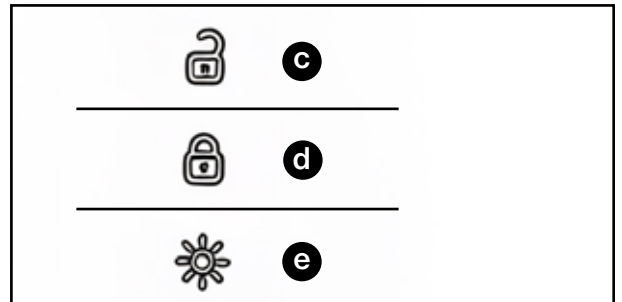
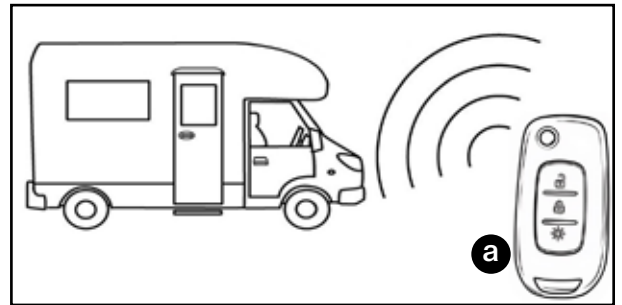

c) Button to open cab doors.

d) Button to lock cab doors.

e) Button for turning on and off the dipped beam headlights.

4.2 Living quarters door

The living quarters door is fitted with sliding mosquito net and sliding blind.



Do not close the living quarters door if the mosquito net is not fully withdrawn.



In case of emergency, the living quarters door is used as a safety exit. Take care not to obstruct the areas near the exit.



- Periodically lubricate hinges and locks with sprays (ordinary maintenance).
- Periodically treat rubber seals with talcum powder.
- For correct ventilation, periodically clean the ventilation grids.

4.2.1 Internal door locking

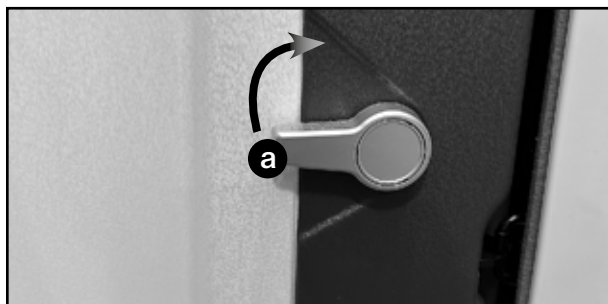

To lock the door from the internal, rotate the lever (a).

 **WARNING**

Do not use alcohol, alcohol-based products or aggressive detergents to clean window and roof light panes. A damp cloth is enough to ensure proper cleaning; if necessary use diluted neutral soap with a lot of water.

5.1 Windows

The windows comprise an external frame, an internal frame and a transparent, double, openable pane which may be of the sliding or top hung type.

The transparent, double panes have an air gap which may absorb damp. Therefore any condensate appearing inside is perfectly normal.

The internal frame encloses the blind and roller mosquito net which are spring-operated. A manual mechanism allows changing their position according to preference.

Should the winding device need maintenance, you are advised to contact an Ahorn Camp authorised workshop, because this operation requires disassembly of the frame.

 **WARNING**

In case of long stops, the blinds of the bathroom window and of the bathroom roof-light must be kept closed.

 **THINGS TO DO**

- Periodically clean the sliding window guides and the top hung window support arms.
- Treat rubber seals with talcum powder.
- Check the locks at regular intervals.

 **THINGS TO AVOID**

- Do not use alcohol or solvents for washing.
- Do not stick self-adhesive labels on the transparent panes.

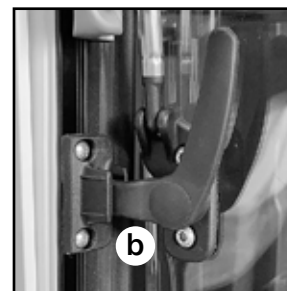

a) Top hung window: internal handle in closing position.

b) Top hung window: internal handle in permanent air vent position.

5.2 Cab windows

 **WARNING**

For a correct use of the cab windows, refer to the chassis manual (V, T and A series).

 **WARNING**

The driver must make sure that all electric equipment and/or devices are used correctly.

 **WARNING**

Before raising a window make sure that it may not have any consequences on the other passengers in the vehicle

 **WARNING**

For safety reasons, leave the vehicle only after having properly removed the key.

 **THINGS TO AVOID**

- Do not leave children unattended in the vehicle, especially when the electric windows may still be activated.

5.3 Roof lights

The roof houses different roof lights, all with compass opening and integrated mosquito net, fixed or sliding.



WARNING

Roof lights are designed to ensure suitable air recycle even when they are closed. For your safety, do not obstruct air grilles.

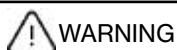

WARNING

When travelling, the roof-lights must be closed while the blinds and the mosquito nets must be open.

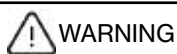

WARNING

When the vehicle is parked under the sun, the blinds must not remain completely closed.



THINGS TO DO

- Lubricate with vaseline, at least once a year, the roof lights equipped with handle seal mechanism.
- Treat rubber seals with talcum powder.
- Make sure there is continuous airing not only in summer but particularly in winter.
- In case of snow, make sure that ventilation is efficient.



THINGS TO AVOID

- Do not drive with the roof lights open.
- Do not obstruct air grilles.
- Do not close the blinds while driving because they may fall out of their guides due to the pressure of air.

5.3.1 Dometic Micro/Mini/Midi Heki

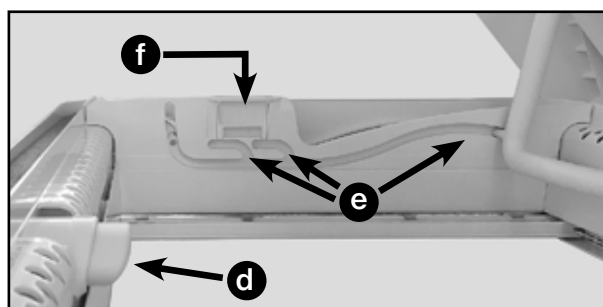
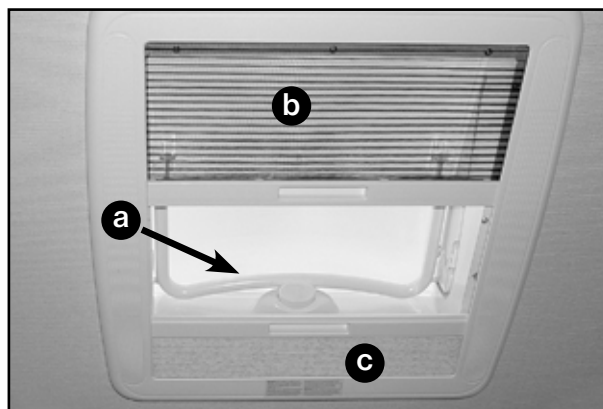

- a) Opening handle.
- b) Sliding mosquito net.
- c) Sliding blind.
- d) Lock button.
- e) Intermediate opening positions.
- f) Intermediate opening positions lock.

5.3.2 MPK 40 X 40

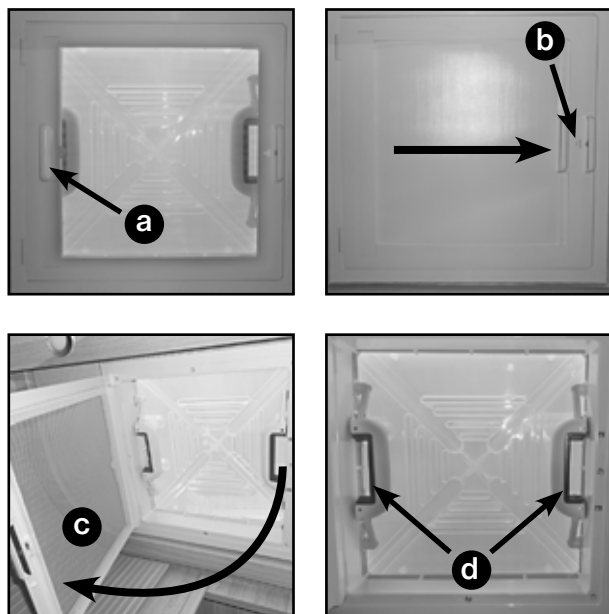

To close the blind, pull up the handle (a) until you find the locking point (b).

To open the roof light, open the mosquito net (c), press the lock buttons (d) situated in the handles and push the roof light cover upward.

5.3.3 MPK 28 X 28

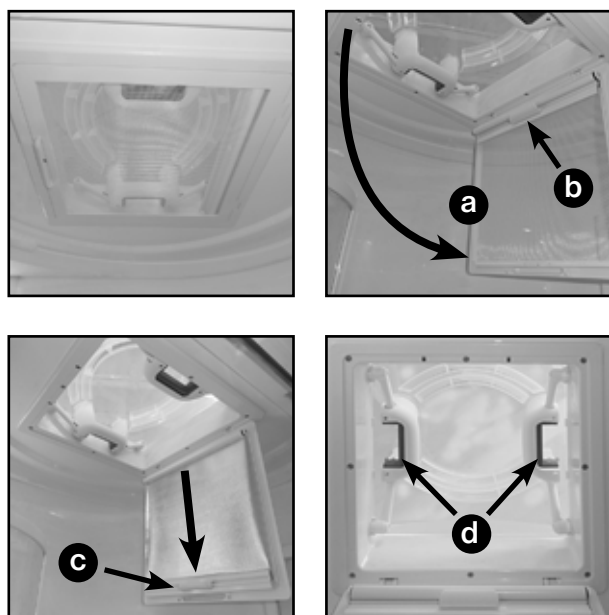

To close the blind, open the mosquito net (a), pull up the handle (b) until you find the locking point (c).

To open the roof light, press the lock buttons (d) situated in the handles and push the roof light cover upward.

5.3.4 Polyplastic StarView

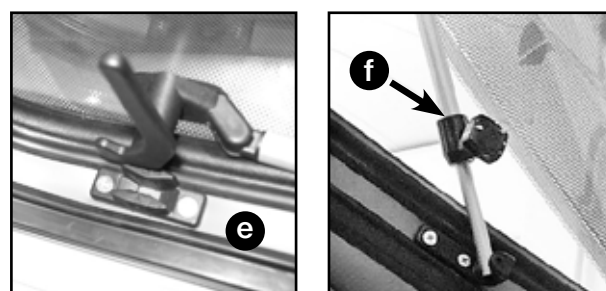
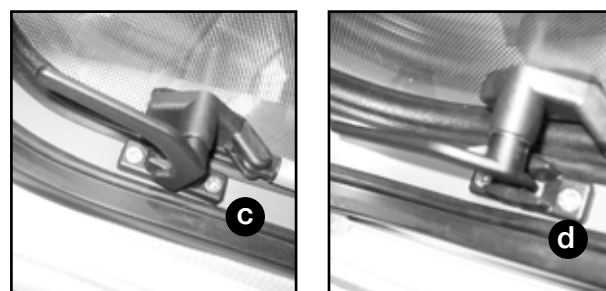
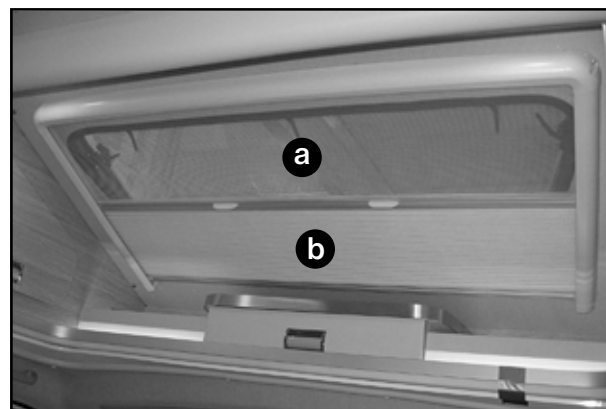

- a) Sliding mosquito net.
- b) Sliding blind.
- c) Internal handle in closing position.
- d) Internal handle in permanent air vent position.
- e) Internal handle in open position.
- f) Knob for fixing the tube stay (open position).

5.3.5 Vehicles with drop-down bed over the dinette (optional)

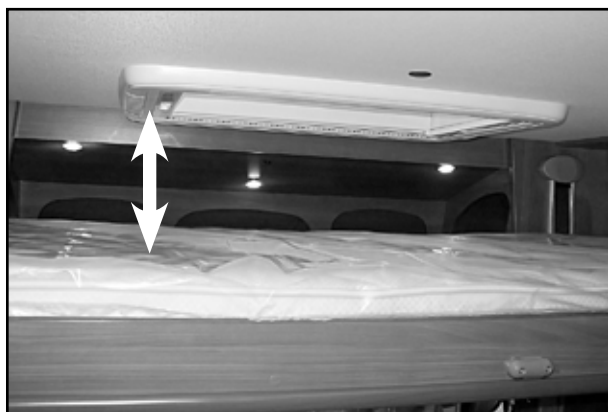

 WARNING

If the vehicle is provided with a drop-down bed over the dinette (optional), when the vehicle is parked for a long time under the sun, the bed must not remain in fully raised position: leave a space of at least 10 cm between the roof-light and the bed mattress.

6.1 Introduction

The electrical system includes a power supply/battery charger, a 12 V distribution control unit fitted with fuses, and a control panel.

The battery charger automatically operates when the vehicle is connected to a 230 V power source, recharging both the auxiliary battery and the engine battery (with holding power only for the latter).

The 12 V distribution control unit includes the appliances controls and the tank and batteries level controls. Each appliance control is protected by a fuse.



THINGS TO DO

- It is advisable to routinely check that the circuit breaker is working properly.
- For the installation of accessories, contact an Ahorn Camp authorised workshop. Never modify the original electrical system of the chassis used for the caravan.
- Inside outlet sockets may only be used with suitable appliances.



THINGS TO AVOID

- Do not insert any metal object or wire in the air vent slots of the power supply.
- No appliance should be used outside when connected to the internal socket.



NOTE

The power supply and the 12 V distribution control unit are located under the left cabin seat.



WARNING

The power supply and the control unit must not be exposed to rain, sources of heat or brought in contact with any conductive or inflammable fluid. Such use may cause short-circuits, fires, or irreversible harm to people, animals or objects.



WARNING

Avoid placing materials in contact with the components of the electrical system, to ensure proper ventilation of the components themselves. Lack of ventilation entails the risk of overheating, short circuits, fires and irreversible damage to people, animals, or objects.

6.2 12 V distribution control unit - Fuses

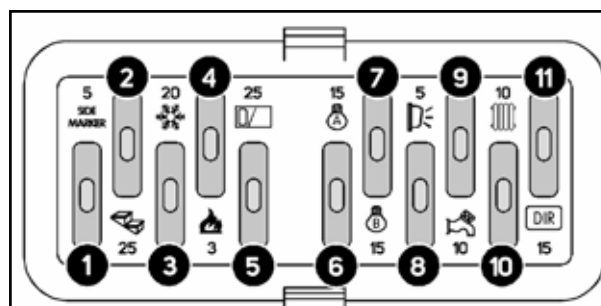

- 1) Side-marker lights.
- 2) Electric entrance step.
- 3) Fridge 12 V power supply.
- 4) Gas hob ignition.
- 5) Electric bed.
- 6) Lights group "A".
- 7) Lights group "B".
- 8) Awning light.
- 9) Water pump.
- 10) Heating.
- 11) DIR output (electric tank heating or satellite antenna).



WARNING

Quantify the loads with skilled personnel before installing electric accessories other than those of the standard outfit and carefully determine the type of connection to be made.



NOTE

For information on the connections of the control unit, refer to the manufacturer's manual.



NOTE

Some fuses are related to optional devices, or are not available on some models.

6.3 Control panel

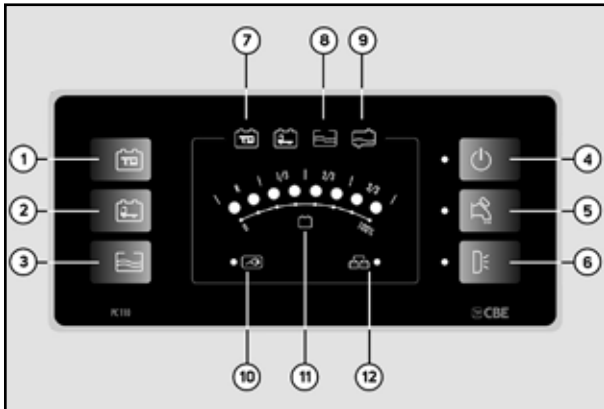

- 1) Button to control auxiliary battery voltage (B2).
- 2) Button to control engine battery voltage (B1).
- 3) Button to control fresh water and waste water tank level.
- 4) On/off main switch. The flashing LED indicates that the auxiliary battery is run down and all the appliances will soon be disconnected.

NOTE

At startup the control panel checks the working of all LEDs.

- 5) Button for pump on and off.
- 6) Awning light control button, switches automatically off when you start up the engine.
- 7) The flashing of this LED indicates that the auxiliary battery (B2) has run down.
- 8) The flashing of this LED indicates that the fresh water tank is empty.
- 9) The flashing of this LED indicates that the waste water tank is full.
- 10) Indicates 230 V power source connection.
- 11) Battery voltage and tank level display.
- 12) Indicates the auxiliary battery charging by means of the vehicle alternator.

WARNING

In case lithium batteries are used, the voltage reading may give incorrect values.

NOTE

Refer to the producer's handbook for further information on the control panel.

6.4 Batteries

6.4.1 Engine battery

The engine battery is located behind the cab step on the left side.

NOTE

When turning on the engine the vehicle's alternator automatically recharges also the auxiliary battery.

WARNING

For maintenance of the engine battery, please refer to the manual provided by the chassis manufacturer.

6.4.2 Auxiliary battery

The auxiliary battery, with protection fuse, is installed inside the settee.

NOTE

When turning on the engine the vehicle's alternator automatically recharges also the auxiliary battery. Recharge can also be achieved, always automatically, through the connection to the 230 V network: the use of this source is recommended whenever possible.

WARNING

Do not leave the appliances turned on for a long period of time without recharging the battery: should the voltage reaches 10 V all the appliances will be automatically disconnected. That occurs in order to avoid damages to the battery.

WARNING

If installing a second auxiliary battery, the batteries cables must be positioned in such a way that no hazards arise. The installation must be performed by specialized personnel. Always contact an Ahorn Camp authorised workshop.

Installation and removal of the auxiliary battery

 WARNING
Switch off all appliances and lamps before connecting or disconnecting the auxiliary battery.

 WARNING
If replacement of the auxiliary battery is required, please only use batteries of the same type and same characteristics of the battery originally installed.

To install/remove the auxiliary battery, proceed as follows.

Installation:

- 1) Make sure that all the appliances are disconnected and the system is not energised.
- 2) House the battery inside the bay and fasten it by the specific fasteners.
- 3) Connect the cables to the terminals, taking care to respect polarities (red/positive - black/negative).

Removal:

- 1) Make sure that all the appliances are disconnected and the system is not energised.
- 2) Disconnect the terminals from the battery poles, taking care to protect the ends of the cables by the specific caps.
- 3) Unlock the fasteners for battery positioning and remove it.

 WARNING
For safety reasons, always protect the battery poles and do not store metallic objects near the batteries (danger of short circuit).

Teleco lithium batteries (optional)

If the vehicle is equipped with Teleco lithium batteries (optional), it is possible to monitor the battery status (residual charge) through an application to be installed on the smartphone. You can download the application using the following QR code:



To save battery power, when the vehicle is not in use, turn off the battery, by pressing the button (a) for 5 seconds.

 WARNING
In case of installing an inverter, ensure that it is compatible with the battery.

 THINGS TO DO
<ul style="list-style-type: none"> • Bear in mind that the battery capacity is limited and lowers considerably in winter. • Disconnect the battery poles in case of maintenance works on the electrical system. • If your vehicle is not going to be in use for a long time, always disconnect the auxiliary battery by removing the relevant fuse (see below "Battery master switch").

 THINGS TO AVOID
<ul style="list-style-type: none"> • Do not overload the lines with electric accessories. • Do not leave the engine turned on when either the engine battery or the auxiliary battery terminals are disconnected (danger of short circuit).

6.5 Power supply - Battery charger



The power supply/battery charger is located under the left cabin seat or inside the settee.

The battery charger can recharge different types of batteries; for optimal battery charger operation, a selector (b) is provided inside the charger that can be accessed by removing the cover (a).

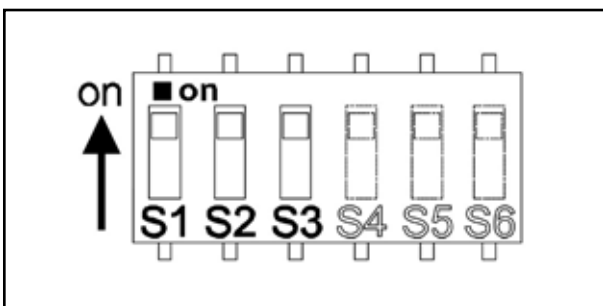
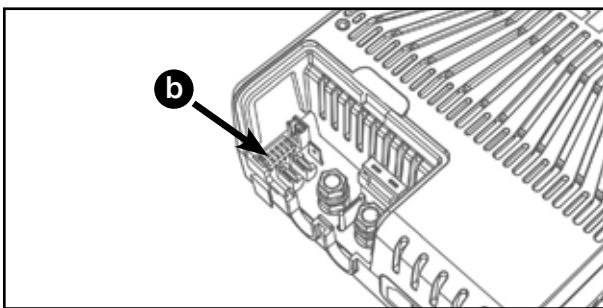
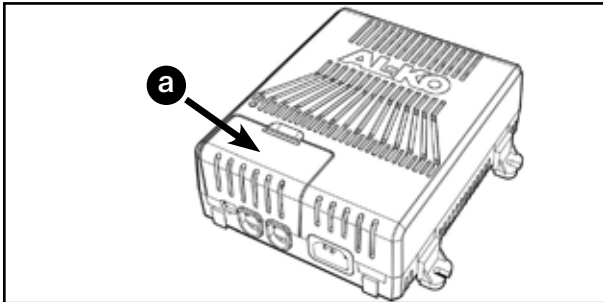

Position the switches S1, S2 and S3 according to the battery in use, following this diagram:

S1	S2	S3	Battery
off	off	off	LiFeP04 (13,9 V)
off	off	on	LiFeP04 (14,2 V)
off	on	off	LiFeP04 (14,4 V)
off	on	on	LiFeP04 (14,6 V)
on	off	off	GEL (14,1V)
on	off	on	Pb (14,4 V)
on	on	off	AGM1 (14,55 V)
on	on	on	AGM2 (14,7 V)



The position of the switches S4, S5 and S6 is not relevant.



Refer to the documentation provided by the manufacturer of the battery to be installed to make sure it is compatible with the battery charger.

✓ THINGS TO DO

- Read the producer's handbook carefully.
- Always maintain open the aeration provided for air recycle.
- Disconnect the power supply before connecting or disconnecting to the battery.
- Minimise the drawing of current while the battery is being recharged (excessive absorption extends charging times and the battery could be damaged).
- If the power cable or the connection terminals to the battery are damaged, they must be replaced with similar items available from the manufacturer or the technical service.
- Before connecting the power supply of the battery charger to a power unit, make sure that the 230 V output of the latter is stabilised.

✗ THINGS TO AVOID

- Do not insert any metal object or other wire in the air vent slots of the power supply.
- Do not obstruct the air intakes on the cover.
- Disconnect the 230 V and 12 V power supply before performing maintenance works.



Warranty is void in case of improper use and the manufacturer shall not be liable for damages to goods or people.

6.6 Booster

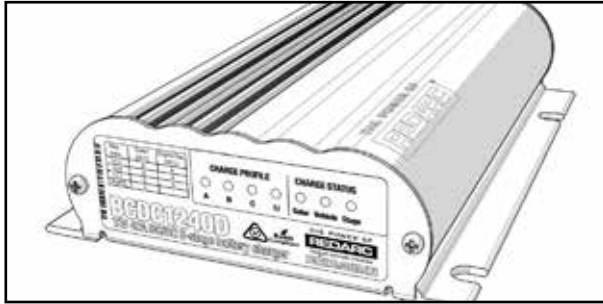

An additional component (booster) is fitted on the vehicles to optimise auxiliary battery charging while driving. The booster is located near the 12 V distribution control unit.

Charging profile



WARNING

The actions described must be performed exclusively by specialised personnel. Always contact an Ahorn Camp authorised workshop.

According to the type of auxiliary battery installed in the vehicle, the booster must be set to the most suitable charging profile. The charging profile is determined by the type of connection of the orange cable:

- Leave the orange cable disconnected to select a maximum voltage of 14.6 V (Profile A).
- Connect the orange cable with the General Earth to select a maximum voltage of 15.0 V (Profile B).
- Connect the orange cable with the red cable (battery positive) to select H profile (profile for heated lithium batteries - 14,2 V) .
- Connect the orange cable with the green cable to select Li profile (profile for lithium batteries - 14,2 V).



WARNING

Check the technical specifications provided by the auxiliary battery manufacturer to ensure that the maximum voltage of the selected profile does not exceed the maximum charging voltage recommended by the manufacturer. Choose another charging profile if the maximum voltage is too high for the type of battery installed.

Inactivity of the vehicle

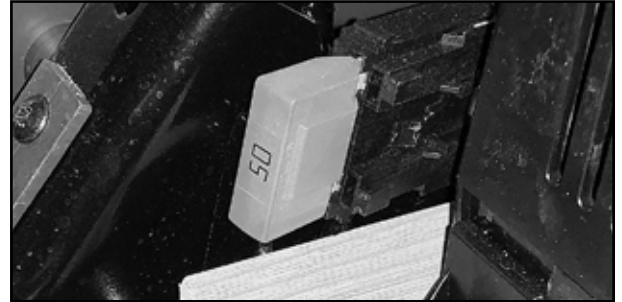

In case of a long period of inactivity of the vehicle, it is advisable to disconnect the booster by removing the 50 A fuse, located near the 12 V distribution control unit.



NOTE

Refer to the manufacturer's manual for more information on the booster.

6.7 Other components

External 230 V socket

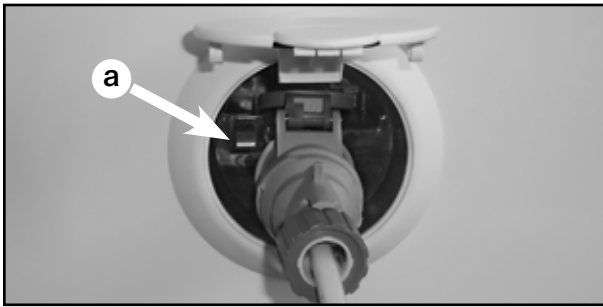

Insert the plug into the socket as shown in the picture. To remove the plug from the socket, hold the lever (a) while pulling the plug.

Main circuit breaker: 230 V switch

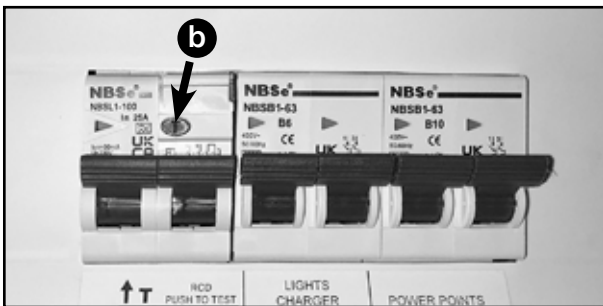

! WARNING

It is advisable to routinely check that the circuit breaker is working properly, by pressing the button (b).

Battery master switch

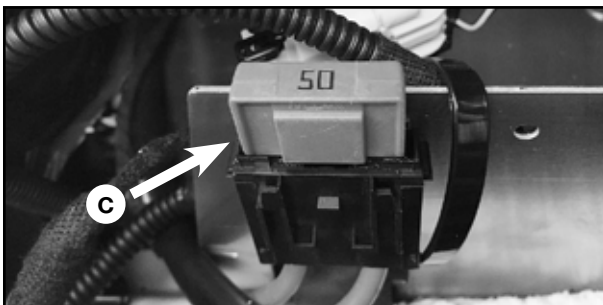

If your vehicle is not going to be in use for a long time, always disconnect the auxiliary battery by removing the relevant fuse (c), located inside the settee (near the battery).

Truma system temperature sensor



Sensor usually installed next to the control panel, required for the operation of the Truma heating system.

USB sockets



There are USB sockets in the living quarters that can be used to charge devices such as smartphones. To supply current to the USB sockets, activate the on/off main switch on the control panel.

Awning light

An awning light is fitted on the right-hand wall of the vehicle. It can be turned on (only when the engine is off) by means of the switch located on the control panel.

7.1 Warning

The absorption refrigerators can operate in three ways, that is to say that they can be powered with: AC at 230 V, DC at 12 V, gas.

Power supply with current at 12 V allows to keep the appliance on also during transfers but it provides only holding power; for this reason, before departure, it is important to cool the refrigerator and the possible food using power supply at 230 V or gas.

Always remember that the refrigerator cooling power is affected by:

- the source of energy it is powered with;
- possible breaks in shifting from one source to another one;
- the ice thickness on the refrigerator's walls that works as insulator (defrost when it exceeds 3 mm);
- the quantity of food inside the refrigerator;
- the climatic conditions the vehicle is exposed to (if parked in the summer sun, inside the vehicle it is possible to reach and exceed 50 °C).

To avoid dangerous food intoxications we recommend to use the utmost care in storing perishable food bearing in mind that the performances of these appliances cannot be compared with those of a household refrigerator.

 WARNING
<p>Read the user guide of the producer before using the appliance.</p>

 WARNING
<p>Periodically clean the back of the refrigerator, accessible through the grids placed on the outer wall of the vehicle and check that there are no spider webs or other objects that obstruct the gas burner.</p>

7.2 LED control panel

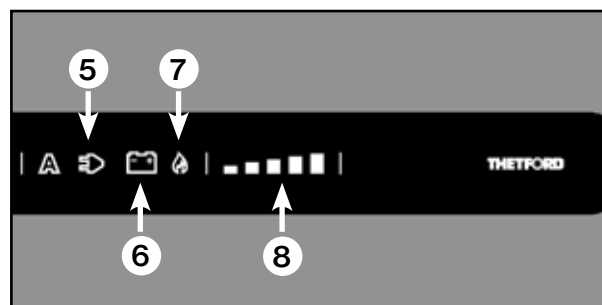
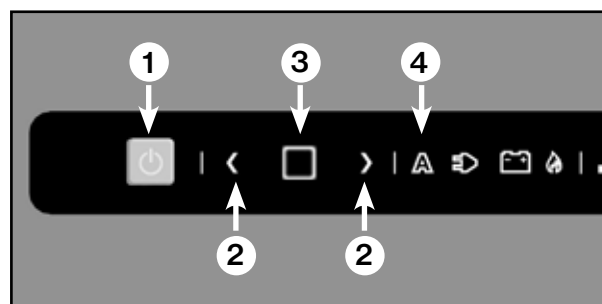

- 1) ON/OFF button.
- 2) Arrow buttons.
- 3) Confirm button.
- 4) Automatic mode pilot lamp.
- 5) 230 V power supply pilot lamp.
- 6) 12 V power supply pilot lamp.
- 7) Gas power supply pilot lamp.
- 8) Cooling level indicator.

Operation

To choose a type of power supply, keep the confirm button (3) pressed for two seconds: the pilot lamps that indicate the type of supply (automatic, 230 V, 12 V, gas) will start to flash. Choose the desired type using the arrow buttons (2). Confirm your choice with the confirm button (3).

To select the cooling level, keep the confirm button (3) pressed for two seconds: the pilot lamps that indicate the sources (automatic, 230 V, 12 V, gas) will start to flash. Press the confirm button once again. The cooling level indicator (8) will start to flash. Choose the desired level using the arrow buttons (2). Confirm your choice with the confirm button (3).

7.3 LCD touchscreen

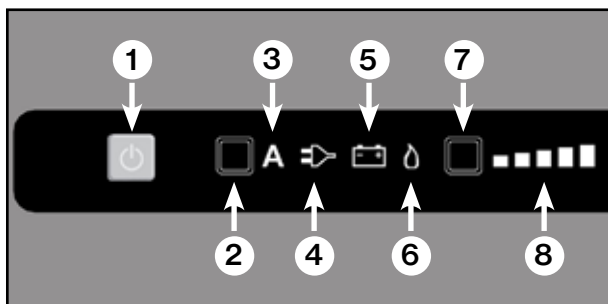

- 1) ON/OFF button.
- 2) Energy source button.
- 3) Automatic mode pilot lamp.
- 4) 230 V power supply pilot lamp.
- 5) 12 V power supply pilot lamp.
- 6) Gas power supply pilot lamp.
- 7) Cooling level button
- 8) Cooling level indicator.

Operation

To select the type of power supply, press the button (2) repeatedly until the desired source is selected.

To select the cooling level press the button (7) repeatedly until the desired cooling level is selected.

7.4 Manual selection of the type of power supply

Gas supply is strictly forbidden during stops at filling stations and when driving the vehicle. For safety reasons, the gas supply can only be selected after 15 minutes have elapsed from the time the engine is turned off. Concerning 12 V or 230 V power supply, if these are selected respectively when the engine is off or without connection to the external power grid, the refrigerator does not operate. For these reasons we recommend the automatic mode, which enables proper and safe operation of the equipment.

7.5 Automatic mode

By selecting the automatic mode, the electronic board will automatically identify the most suitable power supply in the following priority order: 230 V, 12 V, gas. In passing from 12 V to gas, the automatic system requires a waiting period of 15 minutes. This is to prevent the fridge from passing too quickly to the gas supply, when this is not necessary (for example, when a short stop is needed at a fuel station).

NOTE

Refer to the manufacturer's handbook for further information on the refrigerator.

THINGS TO DO

- Use the utmost care in storing perishable food.
- If possible, the refrigerator should be turned on for about 6 hours prior to inserting the food items.
- When parked, level the vehicle as much as possible.
- Defrost when the ice thickness exceeds 3 mm.
- Wash the inside with suitable cleaners when the appliance is no longer in use.
- Treat the rubber door seals with talcum powder.
- Insert the door safety device while travelling.

THINGS TO AVOID

- Do not open the door too often in summer.
- Do not introduce hot food.
- Do not consume perishable foods in case of prolonged refrigeration interruption.
- Do not expose to the sun the wall where the refrigerator is housed
- Do not damage or obstruct the air intakes.
- Do not leave the refrigerator doors closed during a long period of inactivity.
- Do not dismantle the refrigerator on your own.

8.1 General description

The gas system, calibrated at a running pressure of 30 mbar, branches out from the gas bottle locker which is completely sealed with respect to the living quarters and is provided with air grilles directed outwards.

The space available allows housing one gas bottle, with the possibility to house a second gas bottle. Gas bottles must be secured using the fastening belts. The pipes are made of protected steel and connect one or more valves which distribute gas to each appliance.

It is recommended to close the taps of unused appliances and the main valve of the bottle, if no gas appliance is being used.

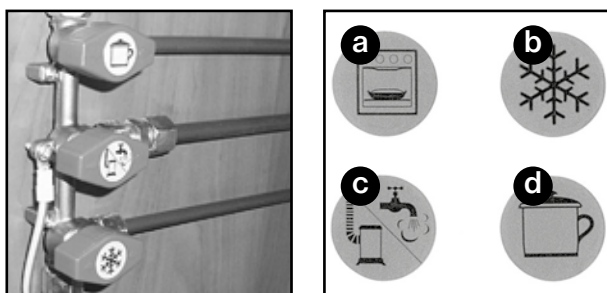

Two, three, four-way taps marked with symbols.

- a) Oven.
- b) Refrigerator.
- c) Heating-boiler.
- d) Hob.

WARNING
During the journey or during stops at filling stations it is forbidden to keep the main valve of the gas bottle open.

WARNING
Before using any gas appliance, ensure that gas system is safe and controlled, and the air inlets of the vehicle are cleaned, both on the roof and on the floor level.

NOTE
During the winter the use of propane gas is recommended (the butane gas does not gasify at temperatures lower than 0 °C).

8.2 Gas pressure regulator with crash sensor (optional)

On some models, the gas pressure regulator is equipped with a safety device (crash sensor) which immediately stops the gas flow in the event of an accident.

WARNING
Some models are not equipped with a gas pressure regulator with crash sensor.

Start up

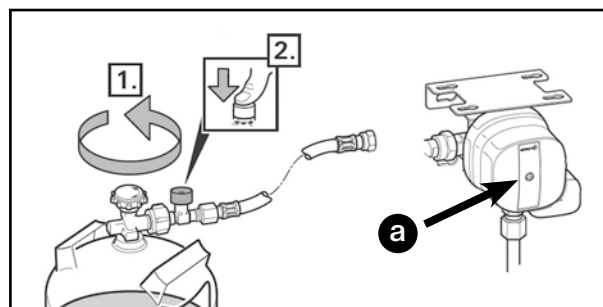

- 1) Open bottle valve.
- 2) Firmly press the hose rupture protection on the high-pressure hose for about 5 seconds.

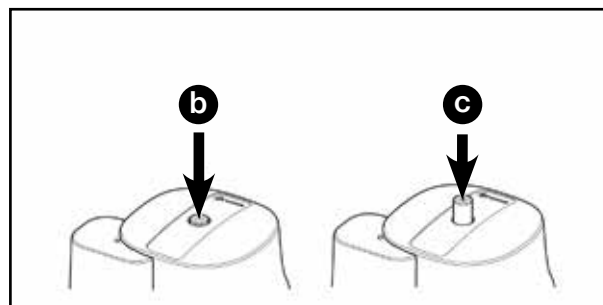

The crash sensor has a yellow reset button (a), the position of which indicates its status: "ready for operation" position (b) or "not ready for operation" position (c). If the reset button (a) is not pressed ("not ready for operation" position), reset the crash sensor. To reset, press the reset button (a) firmly, turn it slightly clockwise, hold it for 5 seconds and ensure that it stays in the "ready for operation" position (b).

NOTE
Refer to the producer's handbook for further information on the gas pressure regulator with crash sensor.

8.3 Gas bottle replacement



WARNING

When connecting or disconnecting the gas bottle and during any handling operations of the gas bottles inside the locker, extreme care must be taken to avoid damaging, stretching or bending the flexible hose.

For gas bottle replacement, follow the procedure below:

- 1) Ensure that the taps of all the gas powered appliances are closed.
- 2) Close the tap of the bottle to be replaced.
- 3) Unscrew the nut which fastens the hose to the tap of the empty bottle.
- 4) Detach the bottle from the fasteners and remove it from the bay.
- 5) Verify the closure of the tap of the bottle to be installed.
- 6) Insert it in the bay inside the bottle housing, fastening it with the specific fasteners.
- 7) Remove the plastic cap which seals the new bottle.
- 8) Remove from inside the cap the new seal and replace the old one at the end of the hose.
- 9) Manually screw the nut of the hose to the new bottle, completing fastening by the specific wrench, in order to ensure seal tightness.
- 10) Slowly open the tap of the bottle, taking care to detect any gas leakage (strong smell of gas or pressure leak noise).



WARNING

Look for any minor leak by means of a soap water solution (never using flames) using a brush, spreading such solution on the areas where a leak is more likely (joints). Bubbles, if any, indicate a leak.



WARNING

Inspect flexible gas hoses regularly for deterioration and renew as necessary with the approved type. Either the expiry date or the production date is marked on the hoses. If the production date is indicated, refer to the regulations in force in your country to determine the expiry date. In any case, the expiry date of the hoses may vary depending on the country you are in.

✓ THINGS TO DO

- Check that the gas bottles are anchored with the special fastening belts.
- Regularly check that the gas bottle hoses are properly connected.
- Have an Ahorn Camp authorised workshop check the tightness of the gas system yearly.
- Transport the gas bottles only inside the gas bottle locker.

✗ THINGS TO AVOID

- Do not obstruct the air grilles of the gas bottle locker.
- Do not use gas appliances with a different working pressure.

8.4 Hob and oven

i NOTE

The oven is optional (not standard).

The stainless steel hob and oven are fitted with thermocouple valves to stop gas delivery if the flame is blown out. To turn them on when they are cold, it is necessary to press and turn the relevant delivery knobs, wait for the flame to light and release the knobs after a few seconds.

! WARNING

Periodically check the proper operation of the thermocouple valves.

i NOTE

We recommend not to place hot pots on the kitchen top.

Hob

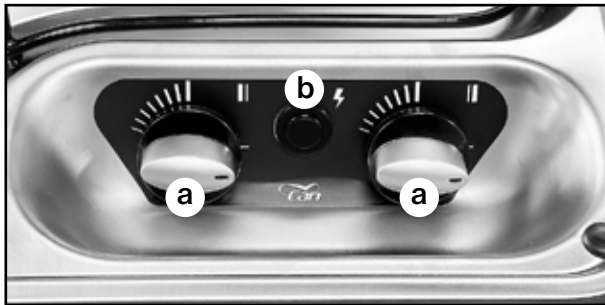

- a) Burner knobs.
- b) Ignition button.

Oven with grill (optional)

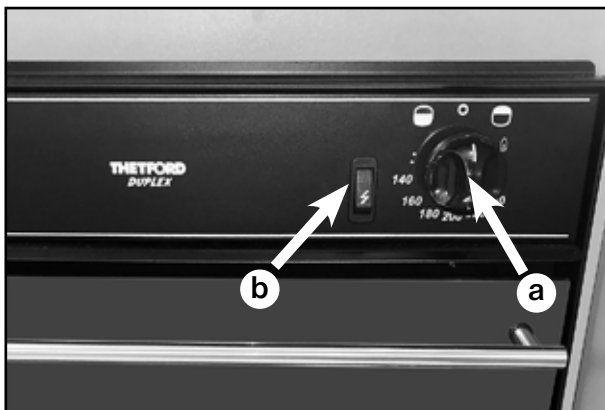

- a) Oven burner knob.
- b) Ignition button.

i NOTE

Please refer to the producer's handbook for further information on hob and oven.

✓ THINGS TO DO

- Push the ignition button only with the oven door completely opened.
- Clean after use with specific oven and stainless steel cleaners.
- After use, carefully dry all stainless steel surfaces.

✗ THINGS TO AVOID

- Do not obstruct the air circulation grilles.
- Do not leave the vehicle unattended when the oven or burners are on.
- Do not insert paper bags (or similar) when heating up food.
- Do not use ovens or burners during the journey.
- Do not close the glass cover of the hob until the gas-rings have cooled off.
- Do not use burners to heat the vehicle.
- Do not use detergents containing chlorine, abrasive detergents, scourers or metal brushes to clean stainless steel surfaces.

 **WARNING**

Before departure it is mandatory to completely empty the hot water boiler.

 **WARNING**

Always remember that in absence of electric power supply the heating system does not work. For this reason during the winter it is recommended to check the auxiliary battery charge frequently and, if connecting to 230 V power supply is impossible, limit the use of the various appliances to the minimum to ensure the battery charge enough to operate the heating system.

9.1 Truma heating system

The Truma heating system consists of a heater with integrated boiler and provides for environment heating and production of hot water.

Hot air distribution is guaranteed by suitably positioned vents.

 **NOTE**

For the correct operation of the heating system, leave all the air vents open.

 **NOTE**

When the heating is turned off and there is the risk of freezing, the boiler empties automatically.

The boiler emptying operation can be either manual, by means of the special switch located on the drain valve, or automatic. The boiler empties automatically when the internal temperature is close to 3 °C. To facilitate emptying operations, leave at least a kitchen or a washroom tap open (it is however recommended to leave all of them open, to prevent water from stagnating inside the taps themselves with consequent damages caused by frost).

 **NOTE**

In case of either automatic or manual emptying, close the drain valve for later use.

9.2 Control panel



All the functions of the system can be programmed by the Truma CP Plus control panel (a). To switch on, operate, and switch off the system, as well as for all the information concerning maintenance and safety, carefully read the manual of the manufacturer, which is provided together with the vehicle documentation.

 **WARNING**

If gas supply is cut-off (for example when a bottle is empty) the control panel might show the following error codes 507, 516 or 517. In these conditions, first of all restore gas supply (for example replacing the empty gas bottle with a new one), then operate the knob/button on the control panel to clear the error (remember that when you press the knob/button for the first time only the panel back lighting might switch on and the knob/button needs to be pressed again). If you delete the error four times without having restored the gas supply first, the control panel locks for 15 minutes (the error code flashes on the display). If the error code is displayed and the control panel switches off/on, the control panel will lock for 15 minutes (the error code flashes on the display). When the control panel locks, no operation is allowed: you need to wait till the end of the lock period (the error code stops flashing) before operating on the control panel again.

9.3 Drain valve

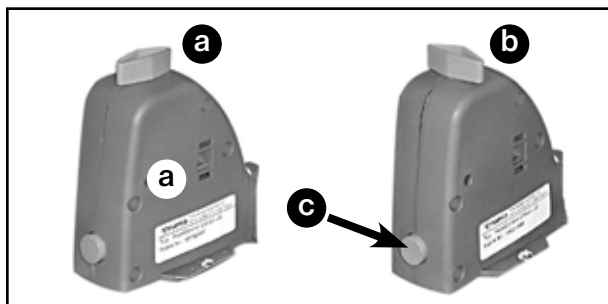

To manually empty the boiler open the drain valve by turning the switch to position (a). After the emptying, close the valve by turning the switch to position (b) and pushing the button (c).

✓ THINGS TO DO

- Check the integrity of the heating flue pipe at regular intervals.
- When there is the risk of freezing, check that the boiler empties automatically.
- During the winter the use of propane gas is recommended (the butane gas does not gasify at temperatures lower than 0 °C).
- Read the producer's handbook carefully.

✗ THINGS TO AVOID

- Do not tamper with the flue pipe. Have all maintenance operations performed by the Ahorn Camp Customer Service or the dealer.

9.4 Electric floor warming unit (optional)

⚠ WARNING

On models with electric floor warming unit, never drill holes in the floor or screw in any screws. Careful with sharp objects. There is danger of a power cut or a short circuit due to damage to a heater wire.

i NOTE

The electric floor warming unit only operates if the vehicle is connected to the 230 V power supply.



Regulator (a) for electric floor warming unit. The electric floor warming unit has four operating levels: 0 (Off), 20 V (low heating level), 22 V (medium heating level), 24 V (high heating level).

⚠ WARNING

Do not cover the regulator. Danger of overheating!

i NOTE

If the regulator is overloaded, the overload protection is actuated. The pin (b) jumps out. Press the pin (b) on the overload protection when the regulator is cooled.

10.1 Introduction

All the Ahorn Camp-models are equipped with a water system expressly conceived to grant a high comfort and a suitable safety level.

Here below you will find some useful advice that will allow you to avoid damages to the system, especially in case of very low temperatures:

- do not use in any case abrasive or acid products to clean the pipes;
- to avoid damage to the water pump, do not open the taps when the fresh water tank is empty;
- in case of frost, the system must be completely emptied (please also read "Maintenance – Inactivity of the vehicle"). It is very important to be sure that no water still remains in the final part of the system, in the taps of the sink and in the lavatory.

10.2 Fresh water tank

 WARNING
<p>It is required before departure to empty the fresh water tank down to 20 litres. This can be done by using the dedicated discharge tap.</p>

 THINGS TO DO
<ul style="list-style-type: none"> • Constantly check the water level in the tanks on the control panel. • Wash and rinse the tanks with water conditioning products at regular intervals. • Empty the system completely when the vehicle is not being used. • Do not keep the taps open when the vehicle is not being used.

 THINGS TO AVOID
<ul style="list-style-type: none"> • Do not leave water in the tanks when the vehicle is not being used. • The water of the tanks is not suitable for drinking, cooking and washing food.

The fresh water tank is located under the rear bed.

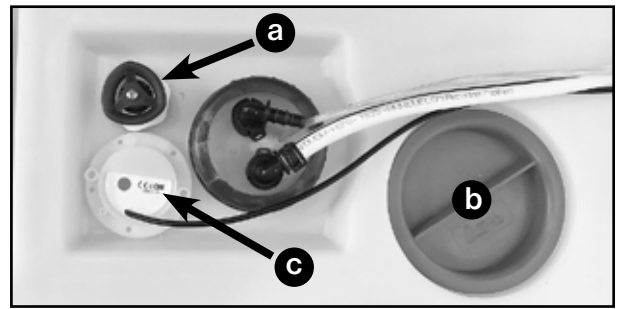

In the upper part of the tank there is the draining tap (a), the inspection cap (b) and the probes (c).

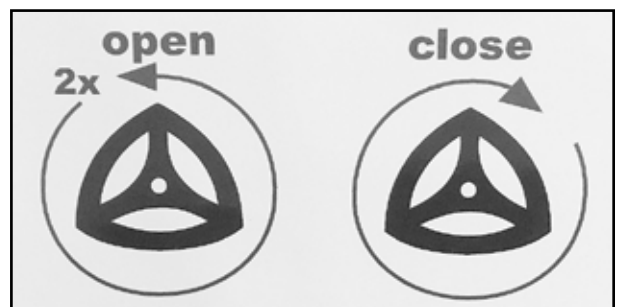
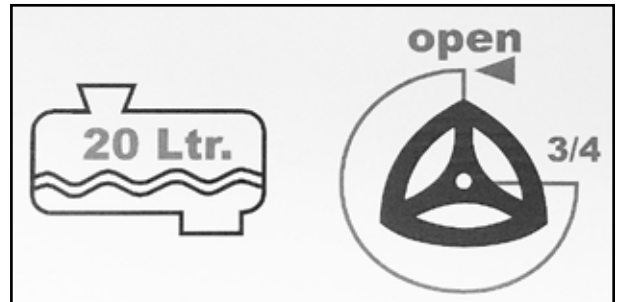

To empty the fresh water tank to the level of 20 litres you need to rotate the tap (a) by three quarters of a turn. If you rotate the tap (a) by two whole turns the fresh water tank will be fully drained.

 WARNING
<p>The tap (a) must be rotated two turns at the most.</p>

 NOTE
<p>The water pump (immersion pump) is located inside the tank. The pump is maintenance-free.</p>

10.3 Waste water tank

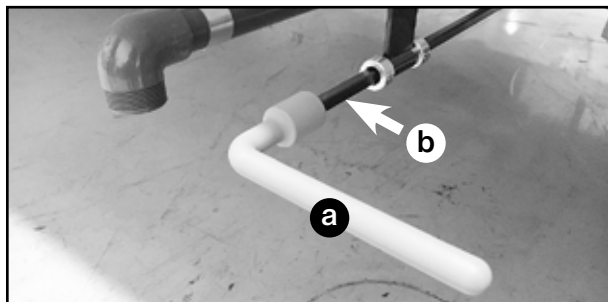

The discharge control is located outside under the floor, on the left or right side, depending on the model. Apply the handle (a) on the rod (b) which controls the exhaust valve. Turn the handle to discharge.

Electric tank heating (optional)

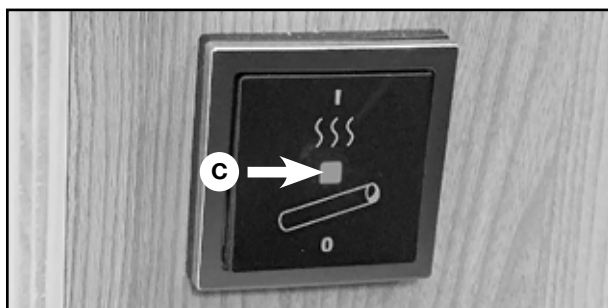

c) Indicator lamp.

Press the switch on "I" to turn on, press on "0" to turn off.

NOTE

The switch is located on the base of the settee.

WARNING

The electric heating of the tank involves a considerable consumption of current: if the vehicle is not connected to the 230 V mains, the battery can run out quickly.

THINGS TO DO

- Constantly check the water level in the tanks on the control panel.
- Drain the tanks without harming the environment.
- Close the drain hole of the shower after each use as it could let out foul odours.
- In winter, add antifreeze, salt or similar products to the waste water (perform this operation with empty pipes and tanks).

THINGS TO AVOID

- Do not pour boiling water down kitchen and bathroom drains.
- Do not use abrasive products for washing the tanks.

 **WARNING**

Wash bathroom plastic parts only with water and neutral soap.

 **WARNING**

In case of long stops, the blinds of the bathroom window and of the bathroom roof-light must be kept closed.

 **WARNING**

When showering, the blind of the bathroom roof-light must be open.

 **WARNING**

Some vehicles have a wooden platform, designed as a floor cover when using the sink. The platform must be removed when taking a shower.

11.1 Cassette-type toilet

This system includes a mobile tank (cassette) that can be removed through a lid on the outside of the vehicle.

 **THINGS TO DO**

- Wash and disinfect the tank using special chemical products at regular intervals.
- Use biodegradable toilet paper.
- Lubricate the seals at least once a year.
- Drain the tanks without harming the environment.
- Read the producer's handbook carefully.

 **THINGS TO AVOID**

- Do not wash the toilet bowl with abrasive products.

A type toilet

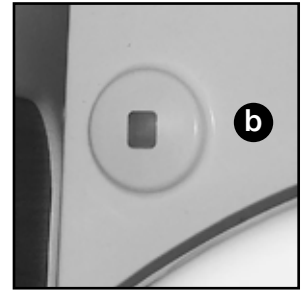

- a) Button for flushing and draining into the tank.
- b) Full tank warning light.

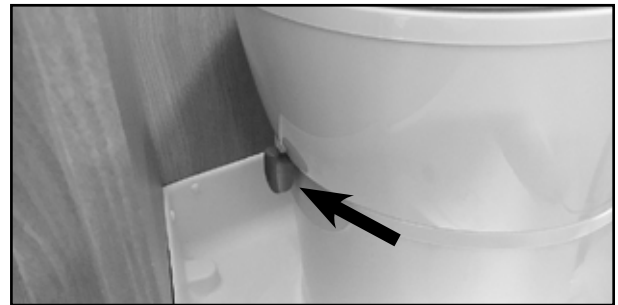

Blade opening and closing handle. To extract the tank first close the blade, pushing the handle in the direction indicated by the arrow.

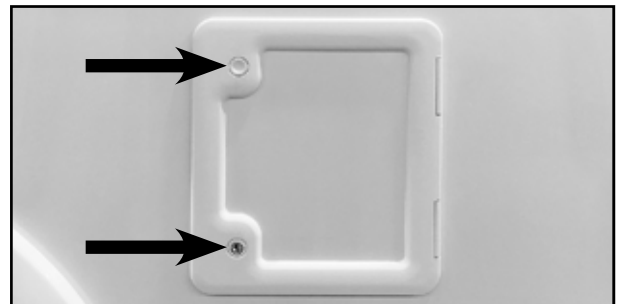

Outside lid which allows access to the tank. To open, press the two buttons simultaneously.



Removable tank (cassette). To remove the tank, pull up the handle (c).

B type toilet

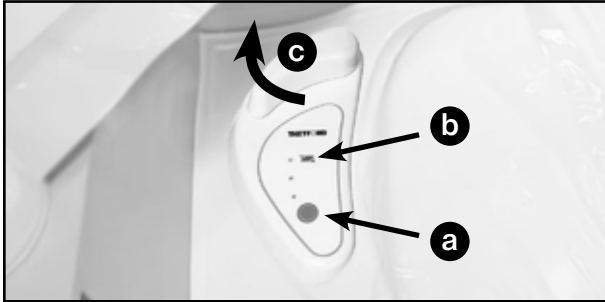

- a) Button for flushing and draining into the tank.
- b) Full tank warning light.

i NOTE

When the flush button (a) is pressed briefly, the display shows the level in the waste tank.

- c) Blade opening and closing handle. To extract the tank first close the blade, pushing the handle in the direction indicated by the arrow.

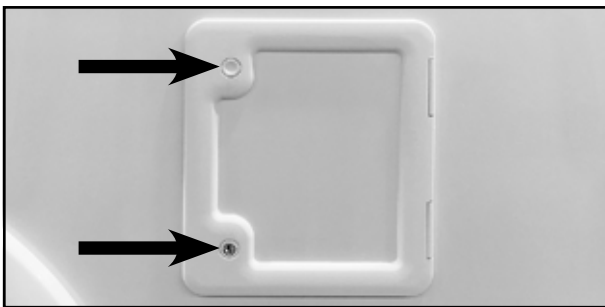

Outside lid which allows access to the tank. To open, press the two buttons simultaneously.

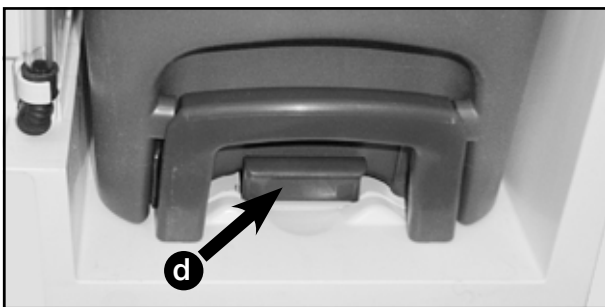

Removable tank (cassette). To remove the tank, pull up the handle (d).

11.2 Shower cab (T 690, A 690)

Some models have been provided with a system that allows them to have a separated shower cabin according to the following instructions:

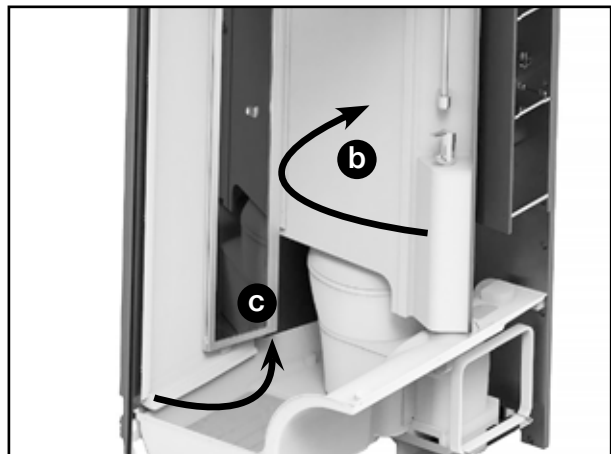

Release the catch (a) (press to unlock), rotate the panel (b) and rotate the panel (c).

11.3 Shower cab (T 590)

To use the shower, rotate the sink to position (a) and lock it with the catch (b).

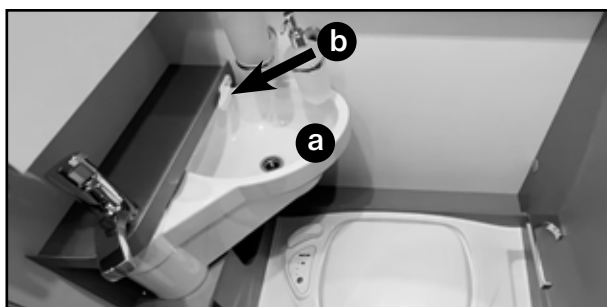

WARNING

While driving, the sink must be rotated to position (a) and lock with the catch (b).

12.1 Table - A type

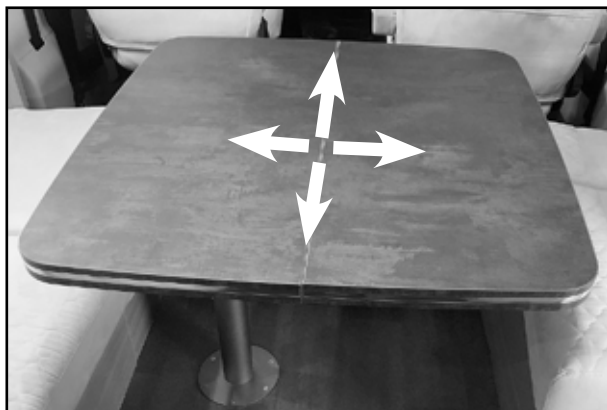

The table top can slide in four directions.

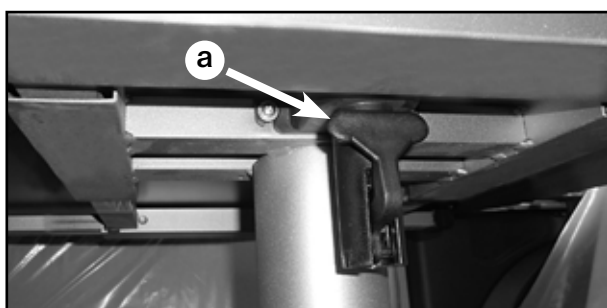

Slide the table top pressing the unlock lever (a) positioned under the table top.

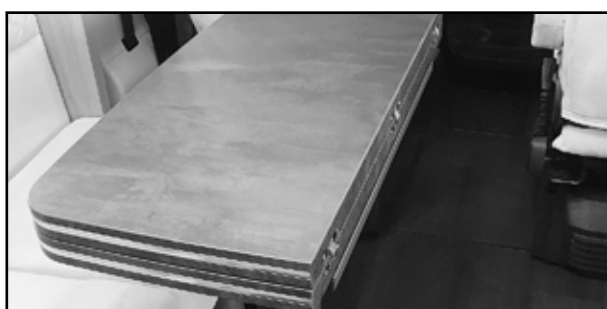
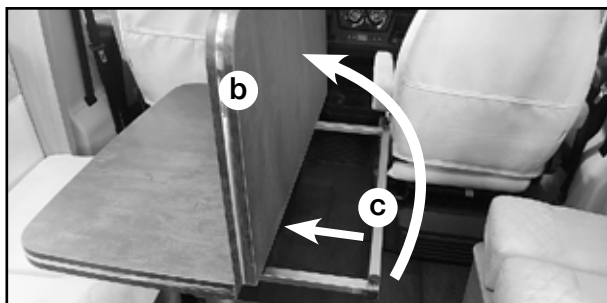

The table top can be closed like a book: lift part (b) and push the support forward (c).

12.2 Table - B type

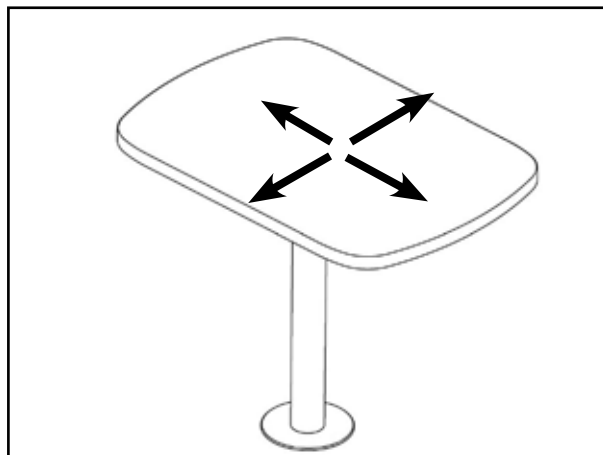

The table top can slide in four directions.

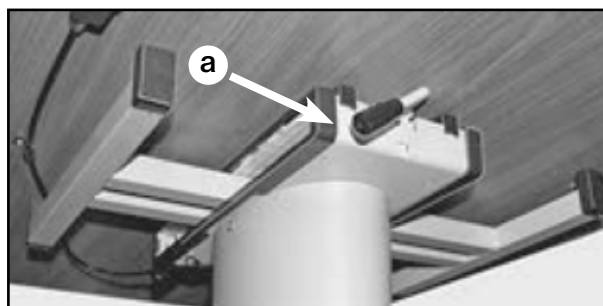

Slide the table top pressing the unlock lever (a) positioned under the table top.

12.3 Table - C type

To lower the table (support position for the bed)

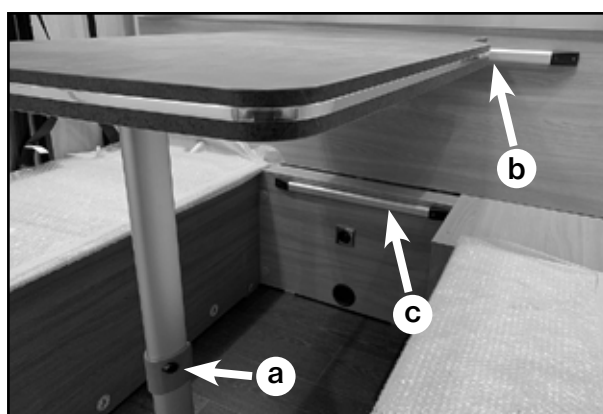

Press the button (a) to fold the table leg.

Lift the table to release it from the upper guide (b).

Hook the table to the lower guide (c).

12.4 Tables with telescopic leg (A type)

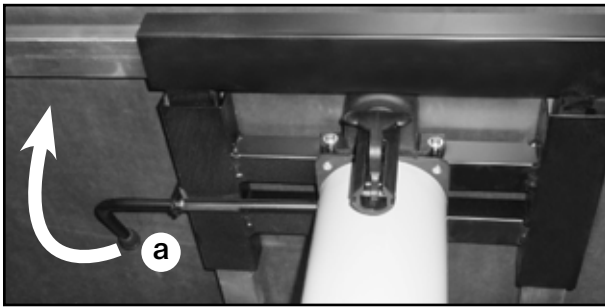

To lower the table, rotate the handle (a) 180 degrees, then push the table to the desired position. Move back the handle to its original position to lock the table.

12.5 Tables with telescopic leg (B type)

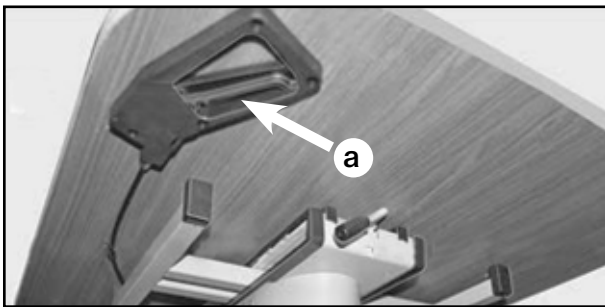

To lower the table, pull the handle (a), then push the table into the desired position. To lock the table, release the handle (a).

12.6 Beds with electric handling (optional)

WARNING
Bed handling by means of electric control should only be performed by adults, and only when the vehicle is parked.

WARNING
During bed handling by means of electric control, ensure that no person or thing is in the operating range of the bed.

12.6.1 Bed above the dinette

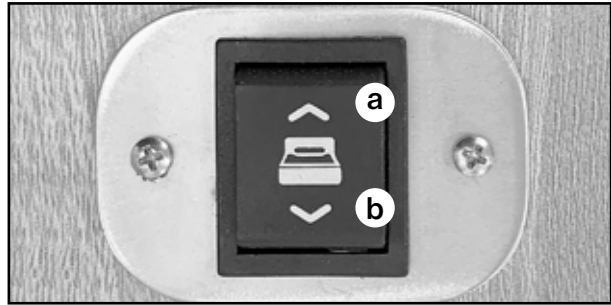

Control panel

- a) Bed up control.
- b) Bed down control.

WARNING
Before lowering the bed, it is necessary to lower the dinette table (night position).

WARNING
Before lowering the bed, remove the headrest and backrests on the dinette.

WARNING
Before lowering the bed, position the cab seats so that they do not interfere with bed movement.

WARNING
When the vehicle is parked for a long time under the sun, the bed must not remain in fully raised position: leave a space of at least 10 cm between the roof-light and the bed mattress.

Manual handling of the bed

In case of malfunction or power failure, the bed can be moved manually using the special handle (a) supplied as standard equipment.

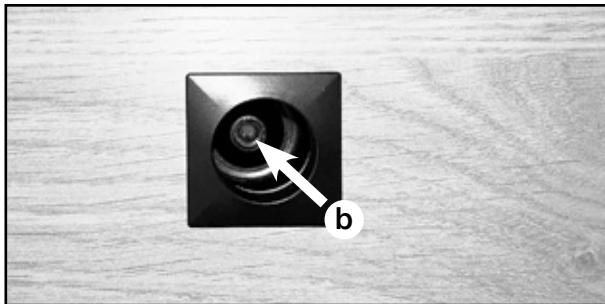
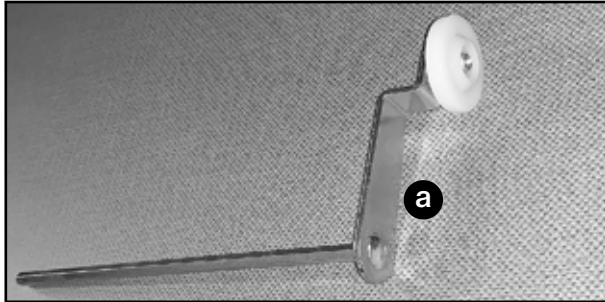

The handle must be inserted in to hole (b) located in the cabinet under the bed surface, on the left side.

12.6.2 Rear bed

The switch (a) for the control of ascent and descent is located under the bed, inside the garage.

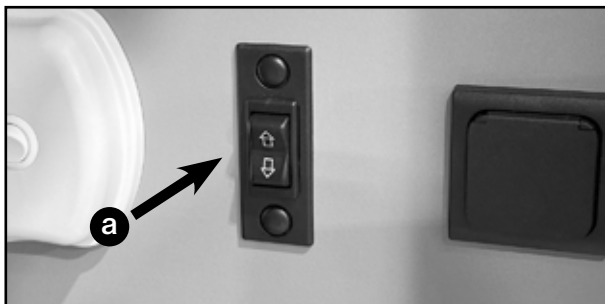

The electric motor is protected by a fuse (see chapter 6 - Electrical system).

Manual handling of the bed

In case of malfunction or power failure, the bed can be moved manually.

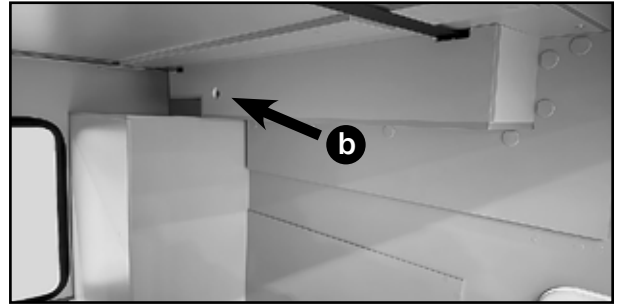

Through the hole (b) located underneath the bed, on the left side of the garage, manually move the bed using a 14 mm T-key (not supplied).

12.7 Other components

12.7.1 Bed safety net

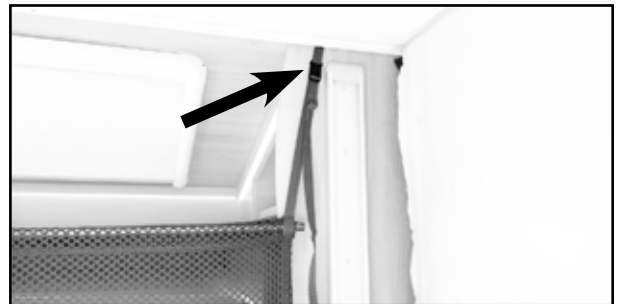

When using the bed, the safety net, if provided, must always be hooked with the straps to the appropriate supports on the ceiling.

i NOTE

The safety net can be under the mattress of the bed.

12.7.2 Cab seating

Both cab seats can be rotated to create the desired living area.



Seat release lever



WARNING

Be sure to always open the door next to the seat before swivelling it. Risk of damage.

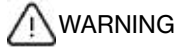

WARNING

Rotation can be carried out in any seat position setting (seat all the way forward, all the way back or in middle positions). In some positions, seat rotation can cause seat interference with cab components. Always proceed with care when rotating, making sure that no seat parts collide against cab components.



WARNING

Take special care when rotating: the seat can cause damage to persons and/or objects near the seat itself.

13.1 Lengthways settee

On the vehicles with lengthways settee (B type), it is necessary to perform the operation described below to obtain an additional passenger seat.

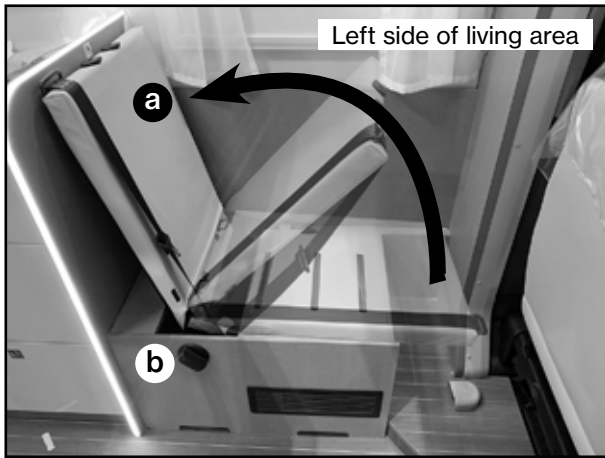

Unlock the backrest (a) with the knob (b) and pull it up.

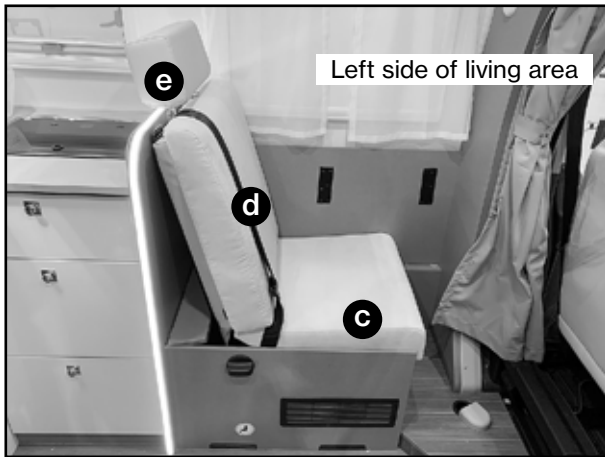

Add the cushions (c), (d) and the headrest (e).

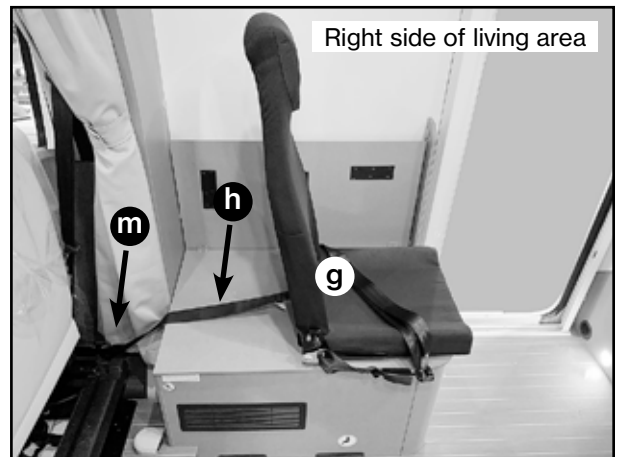
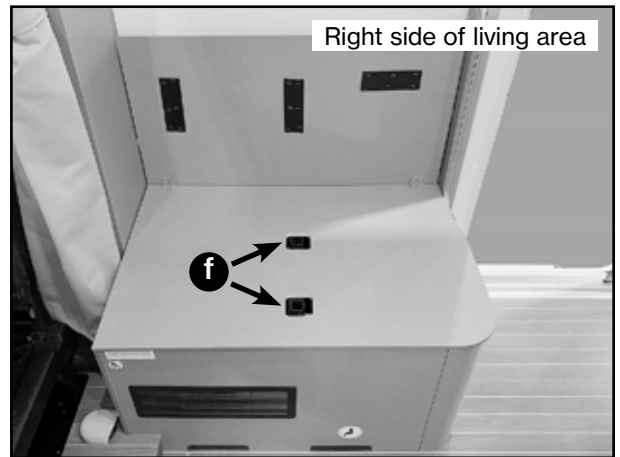

Fit the seat (g) in the holes (f) of the settee. Fasten the belt (h) at the point (m).

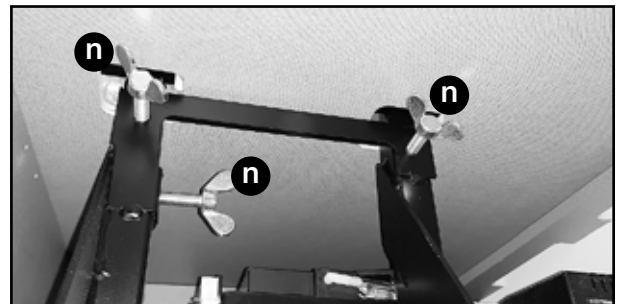

Tighten the clamps (n) inside the settee.

13.2 “L”-shaped settee

On the vehicles with “L” shaped settee, it is necessary to perform the operation described below to obtain an additional passenger seat.

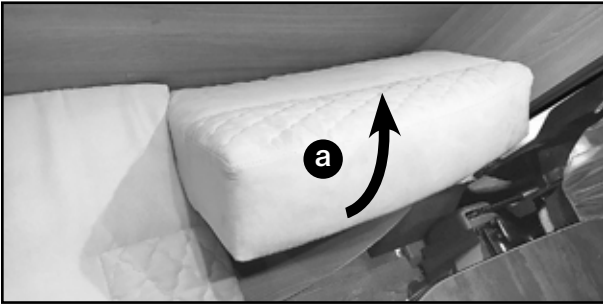

Remove the cushion (a).

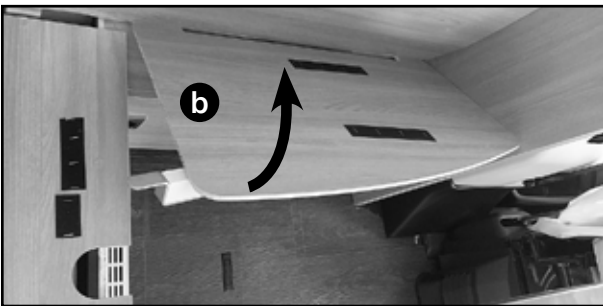

Remove the panel (b).



 **WARNING**

During travel, the panel (b) must be stored in a closed compartment.

In some models it is possible to transform the dinette into a temporary bed (optional), for one or two persons. To obtain the bed surface, it may be necessary to lower the table and/or use mobile supports, fold-down panels, etc. The bed is then completed using the cushions of the sofas and additional cushions supplied.

14.1 T 640, T 680, TE 740, TQ 740

To convert the dinette into a bed, lower the table (open the two supports "a"), then position the cushions as shown in picture.

i NOTE
In some models it is not possible to transform the dinette into a bed.

i NOTE
The bed obtained from the transformation of the dinette, while representing a valid solution, cannot provide the comfort of a bed with a real mattress.

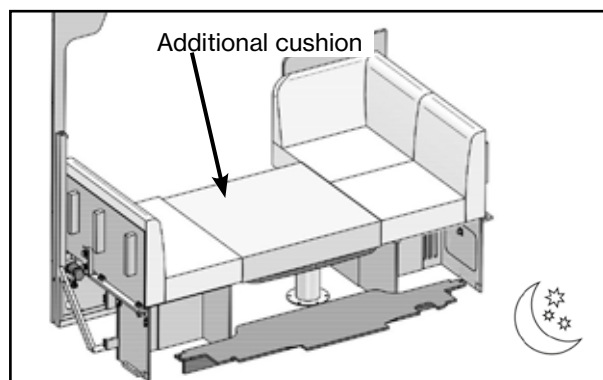
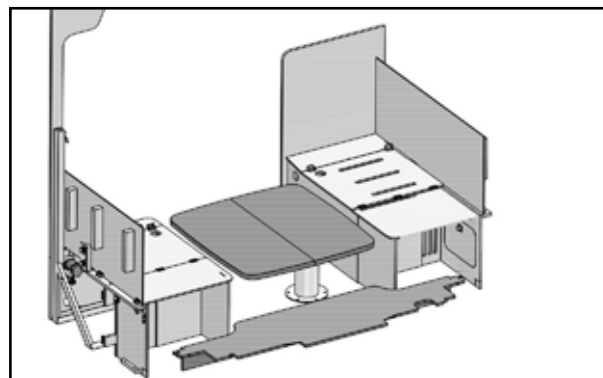
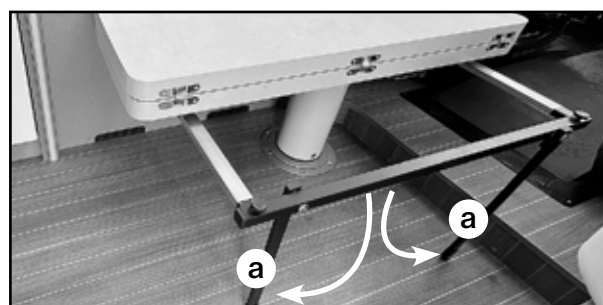
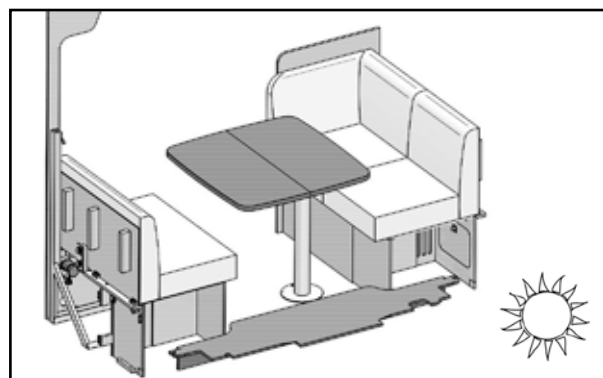

14.2 T 690, A 690

To convert the dinette into a bed proceed as follows.

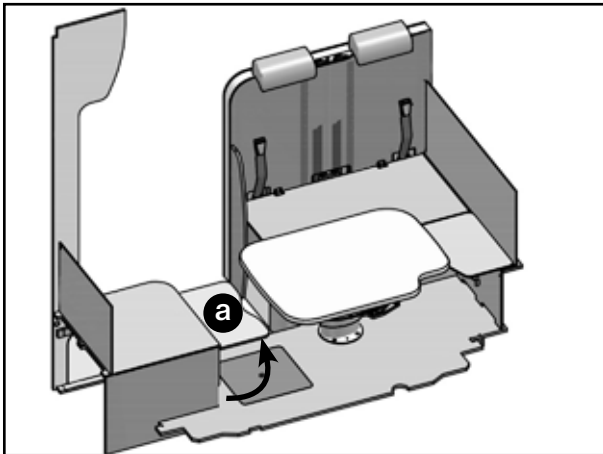
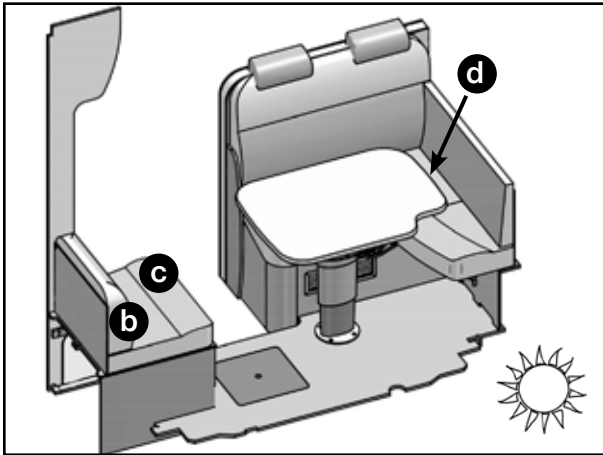

Lower the table and pull up the tilting piece (a).

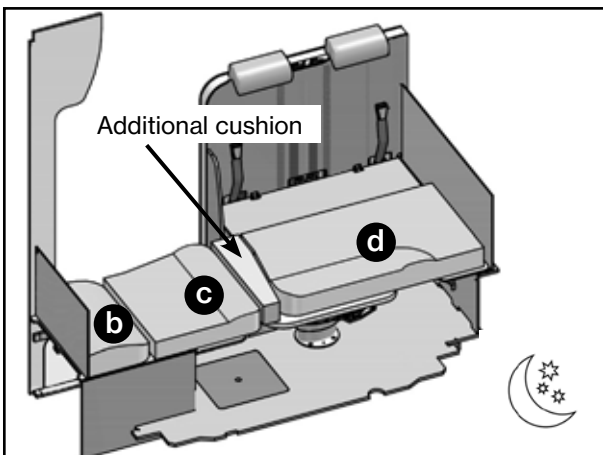

Position the cushions as shown in picture.

14.3 A 720

To convert the dinette into a bed, lower the table, then position the cushions as shown in picture.

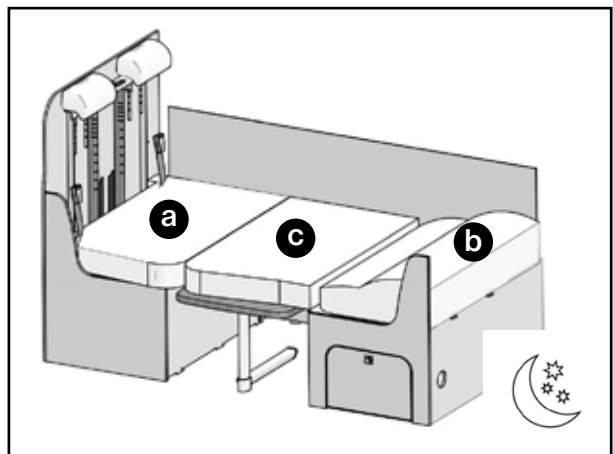
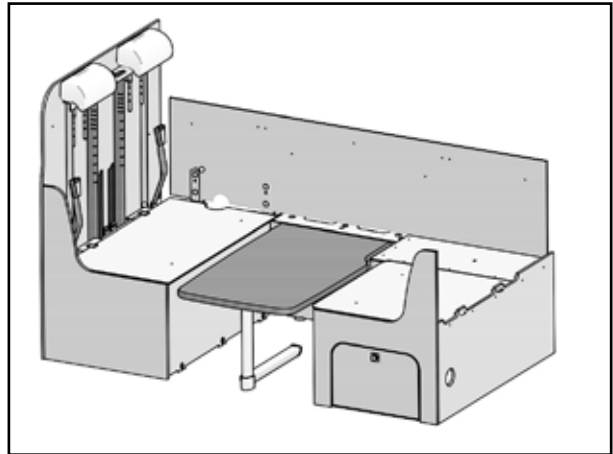
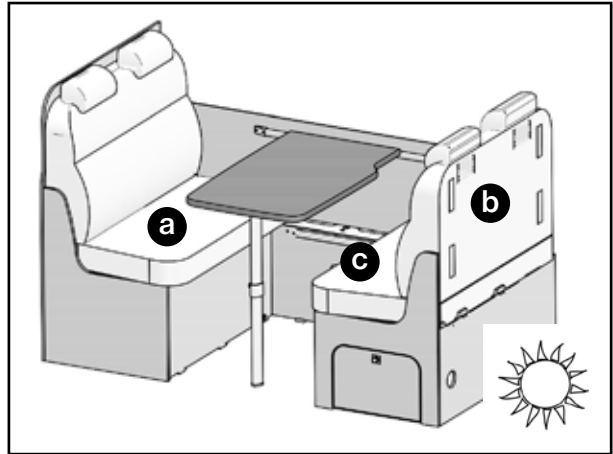

14.4 T590, A595

To convert the dinette into a bed proceed as follows.

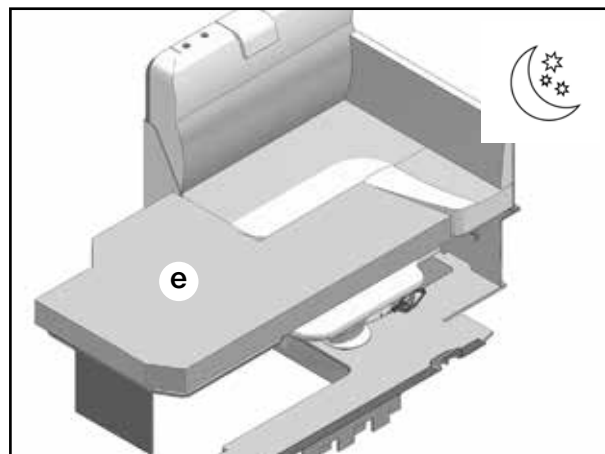
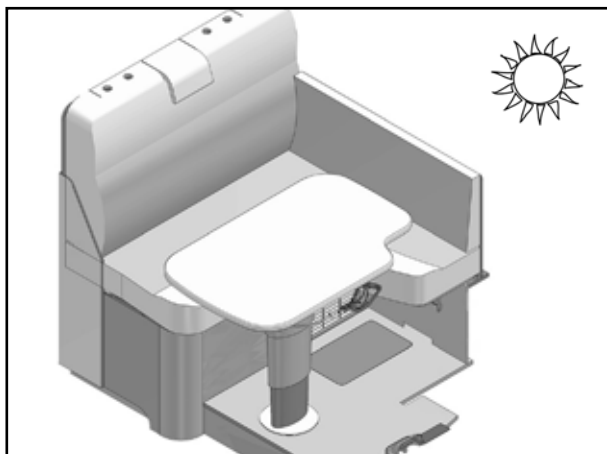

Apply the additional cushion (e).

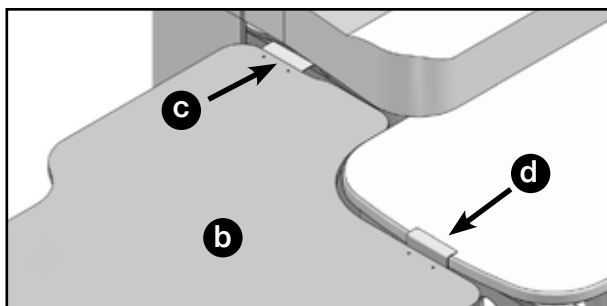
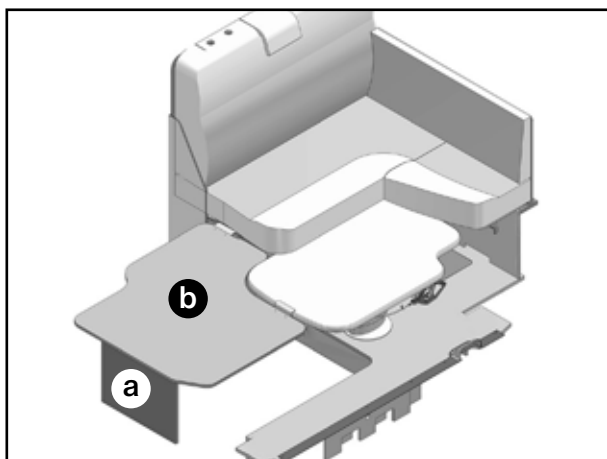

Lower the table (see paragraph 12.5). Open the support (a) and hook the additional top (b) to the settee at point (c) and to the table top at point (d).



THINGS TO DO

- For the installation of accessories, contact an Ahorn Camp authorised workshop.
- In the interest of safety, replacement parts for an appliance must conform to the appliance manufacturer's specifications and should be fitted by him or his authorised agent.



THINGS TO AVOID

- Never modify the original electrical system of the chassis on which the motorhome is built.



WARNING

The failure to use genuine accessories or spare parts may cause damage to the vehicle or compromise the safety of the passengers. The assembly of them, if it has not been carried out following the vehicle manufacturer's instructions, may also invalidate the guarantee. You are therefore advised to use only genuine Ahorn Camp products and to have them installed at authorised service centres only. Any alteration to the vehicle and its systems (electrical, gas, water, etc.) not authorised in writing by Ahorn Camp involves the automatic invalidation of the guarantee.



WARNING

If accessories are installed, it is mandatory to follow the instructions and recommendations indicated by the manufacturer of the accessory installed.



WARNING

Always check to see if the installation of an accessory affects the permitted speed limit.



WARNING

Accessories called "rack carrier systems" for carrying loads in the rear area are not foreseen by Ahorn Camp, their use may cause damage to the vehicle or compromise the safety of the passengers.

15.1 Safety

Bicycle rack

- Do not exceed maximum load allowed.
- Do not use the bicycle rack for other purposes.
- Always ensure that bicycles are securely fastened.



WARNING

In case of carry loads protruding from the shape of the vehicle, always inquire about the regulations in force in the country where you are traveling.

Awning

- Do not open the awning where it is not allowed.
- Do not open the awning in case of bad weather (e.g. strong winds, rain, snow).
- When you close the awning, the cloth must be perfectly dry and clean.

Stabilising jacks

- In some cases, the use of the stabilising jacks can transform parking in camping: always find out about the laws concerning parking and camping in the specific area.
- Make sure to remove the stabilising jacks before leaving.

Satellite antenna

The satellite antenna can only be activated with the ignition key set to the "STOP" position. If the ignition key is in the "MAR" position or if the engine is on, the satellite antenna will close automatically if open. Pay the utmost attention when opening and closing the satellite antenna (both manual and automatic) as the antenna can interfere with roof lights located nearby, if these are open.



WARNING

Close all roof lights when setting the satellite antenna into operation.



WARNING

Before the start of any journey, please make sure that the satellite antenna is in the lowered position.

16.1 Tyres

16.1.1 General warnings

- Six years after the date of production, tyres are to be replaced as, in the long run, rubber deteriorates and tyres are no longer safe after this period has elapsed. The date of production is indicated by the four-figure code positioned on the tyre side, where the first two figures indicate the week of production and the last ones indicate the year.



Example: week 14, year 2025

- At regular intervals check the condition of the tyres and in particular the depth of the tread: the minimum depth is fixed by law.
- At regular intervals check that the bolts of the wheels are tightened; tightening must be done “crossing” (passing from one bolt to the one positioned across from it and not to the one on the right or left-hand side). Check the tightening after the first 50 km traveled with the replaced wheel.
- When the tyres are new, for the first 100 km it is advisable to drive with care and at a particularly low speed, because when new the tyres do not ensure a perfect grip.
- All the tyres mounted on the coachbuilt must be of the same type, dimension and version (for example, do not mount summer and winter tyres on the same vehicle at the same time).
- See the log book for information on the tyres and rims approved for the vehicle.
- Always observe the local legal requirements regarding the use of winter equipment (e.g. snow tyres, chains). The vehicle driver is responsible for ensuring that the vehicle complies with these regulations.

WARNING

In case of a long period of inactivity of the vehicle, tyres could deform with serious consequences in the driving position of the vehicle and its security; we recommend to move the vehicle frequently, to avoid this kind of inconvenient.

16.1.2 Tyre pressure

Correct tyre pressure varies depending on the type of tyre, its size and the load on each individual axle.

NOTE

The load on each individual axle depends on the accessories installed and baggage transported, in addition to standard equipment and also optional equipment.

See the chassis manufacturer manual for information on correct tyre pressure.

Take into consideration that:

- an insufficient or excessive pressure results in an irregular wear of the tyres and in anomalies in the driving position of the vehicle;
- in case of low pressure, tyres can explode;
- pressure must be checked when the tyres are cold.

WARNING

Tyre pressure must be checked at regular intervals, especially after periods (even short) when the vehicle is not used.

WARNING

In case the original tyres are replaced (for example, with winter tyres), the recommended pressure level for the replacement tyres may be different from the level recommended for the tyres fitted as standard equipment. Consequently, it is mandatory to always follow the instructions provided by the tyre manufacturer.

16.2 Cleaning

 NOTE

Any differences in the shade of components in contact with each other may be caused by differences in their basic materials.

16.2.1 Interior

- Never use abrasive products. Use cleaners and household products.
- Do not use detergents containing chlorine, abrasive detergents, scourers or metal brushes to clean stainless steel surfaces.
- After use, carefully dry all stainless steel surfaces.
- Clean furniture and painted surfaces using a wool moist cloth. If necessary use furniture polishes.
- To clean plastic materials (e.g. washroom components) only use water and neutral soap.
- Do not use corrosive products to clean the drains.
- Only clean the dashboard by using a moist cloth.

16.2.2 Upholstery

The elements of the upholstery of the Ahorn Camp vehicles are manufactured with fabrics with different compositions which require different types of treatment. To wash them, refer to the labels applied on the fabrics, indicating their composition and how to treat them.

The labels are in the following locations:

- settee cushions: in the driving direction backrest or in the side backrest;
- cab seats covers: in the backrest;
- cab carpet: in the internal side.

 WARNING

Upholstery fabrics are sensitive to direct ultra-violet light (sunlight or halogen light) and may fade over time. As far as possible, protect the cushions from sun rays.

 WARNING

Do not expose upholstery fabrics to direct heat sources.

 WARNING

Genuine leather and eco-leather cushions are less resistant to abrasion and fading than other fabrics. This is due to the nature of the product and does not indicate any defect.

 WARNING

Gently clean the eco-leather cushions with a soft, damp cloth. Do not use abrasives or chemical detergents.

16.2.3 Exterior

- Do not use high pressure cleaning devices.
- Use delicate detergents specific for aluminium.
- Pay close attention to the parts on which labels and adhesive graphics are present. These parts are more delicate.
- Do not use alcohol to clean the window panes or any other plastic parts.

16.2.4 Tanks

For a good maintenance, it is recommended to clean the fresh water tank and the waste water tank before a long period of inactivity of the vehicle, and however at least once a year.

Proceed as follows:

- 1) Open the inspection cap of the fresh water tank and remove any residues that may be present.
- 2) Fill the fresh water tank and the waste water tank up to about half its capacity, by adding the specific commercial disinfectants. Follow the instructions in the disinfectants.
- 3) Drive the vehicle for a short route in such a way that the water inside the tanks moves.
- 4) Empty the tanks and rinse them with plenty of clean water.

 WARNING

Drain the tanks without harming the environment.

16.3 Flooring

The surface of the floor must be treated with utmost care. Only use neutral soap diluted in water for cleaning and rinse with cold water. Do not use steam cleaners, aggressive detergents or abrasive sponges.

 WARNING
<p>The surface of the floor is soft and sensitive to shocks: heavy and/or sharp objects falling on the floor might cut or scratch it. Even objects rubbing or sliding continuously on the floor might damage it.</p>

 WARNING
<p>Pay attention when putting ladders or stools on the floor: if used inappropriately, the surface might be damaged. When heavy loads are laid on the floor, the floor should be protected.</p>

 WARNING
<p>Certain types of shoes (such as heeled shoes) and the presence of foreign bodies under the sole (such as small stones) might damage the floor.</p>

 WARNING
<p>Any rubber object (such as tyres) laid on the floor might damage it.</p>

Carpets

It is not advisable to place any type of carpet, rug, mat, or cloth on the floor.

Especially avoid the use of carpets with a rubber or latex bottom.

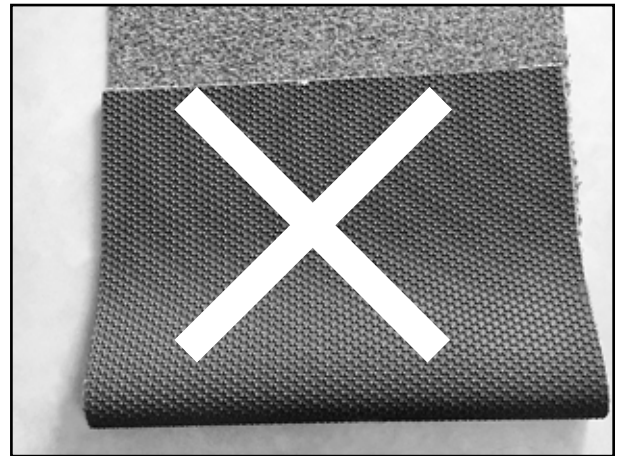

 WARNING
<p>The use of any type of carpet can cause stains or marks to appear on the floor.</p>

 NOTE
<p>Flooring can be covered using original Ahorn Camp carpeting.</p>

16.4 Furniture

Doors and cabinet doors require periodic adjustment to ensure they continue working properly. You are advised to contact an Ahorn Camp authorised workshop when work on the doors and cabinets is needed.

 WARNING
<p>All wooden parts must be carefully kept dry, as moisture can deteriorate them.</p>

16.5 Headlights

Condensation can form in the outer headlights of the vehicle. This is due to atmospheric conditions and is completely normal. No maintenance is required.

16.6 Inactivity of the vehicle

Either before or after a long period of inactivity or in case of frost, also for a short period of inactivity, it is necessary to carry out some operations.

16.6.1 In case of danger of frost

Water system

In case of danger of frost, also for a short period of inactivity, the water system must be fully emptied. Operate as follows:

- empty all the tanks;
- open all the washroom and kitchen taps;
- operate the rinsing of the toilet;
- open the boiler valve.

Batteries

Remember that the batteries can be damaged if exposed to severe cold for a long time: in this case it is advisable to remove and shelter them.

16.6.2 Before a long period of inactivity

Before a long period of inactivity, to take care of your vehicle it is necessary to carry out few but important operations:

- Empty the water system completely (see "In case of danger of frost") and rinse the various tanks.
- Disconnect the auxiliary battery by means of the proper switch or by removing the relevant fuse.
- Disconnect the terminals of the battery or recharge the battery at regular intervals by starting the engine.
- Close the main valve of the gas bottle as well as all the taps of the various appliances.
- Clean the refrigerator and the freezer and leave the doors open.
- Leave sliding blind on roof lights open (except for washroom).
- At regular intervals ventilate the living quarters completely by opening all the doors, windows and roof-lights.



If the vehicle is covered with protective tarpaulins, apply them in such a way that they do not cover the vehicle's ventilation openings or use permeable (breathable) tarpaulins. The use of tarpaulins, in any case, can cause the formation of stains, spots, mold and damage the surfaces, both external and internal, of the vehicle. It is recommended to periodically check that there is adequate air circulation both inside and outside the vehicle and that no moisture is formed.

16.6.3 After a long period of inactivity

After a long period of inactivity, for safety reasons, it is necessary to perform some checks on the conditions of the vehicle:

- Check the perfect efficiency of both the gas system and the electrical system.
- Check that the heating flue pipe is not clogged (e.g. by snow, ice, leaves, insect nests, etc.).
- Clean the back of the refrigerator, accessible through the grids placed on the outer wall of the vehicle and check that there are no spider webs or other objects that obstruct the gas burner.
- Check the tyre pressure and the braking system.
- Thoroughly rinse the fresh water tank and fill it.
- Connect the batteries again.
- Recharge the auxiliary battery completely by connecting to an external 230 V socket.

16.7 Renault chassis number

The Renault chassis number can be accessed through a small hatch located in the cab, at the bottom right hand side.

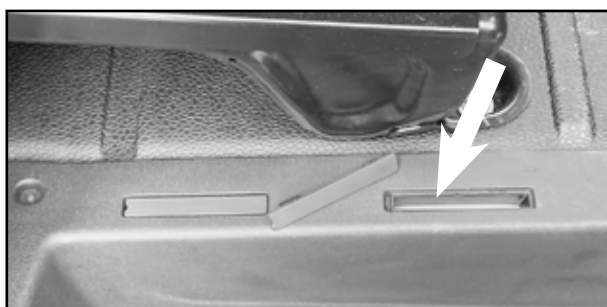
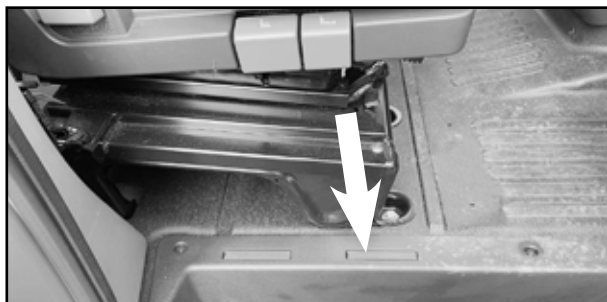

NOTE

For further information about Ahorn Camp vehicles and for technical data of the models, please visit the following website: www.ahorn-camp.de

16.8 Customer service

16.8.1 Spare parts and accessories

Ahorn Camp dealers are always available for advice of any kind, repair operations and supply of spare parts and/or accessories.

We recommend always accurately indicate to your dealer the model, chassis number and year of first registration (indicated on the registration card) to simplify the exact identification of required spare part. Ahorn Camp spare parts and accessories have been designed for use expressly on Ahorn Camp vehicles.

WARNING

The failure to use genuine accessories or spare parts may cause damage to the vehicle or compromise the safety of the passengers. The assembly of them, if it has not been carried out following the vehicle manufacturer's instructions, may also invalidate the guarantee. You are therefore advised to use only genuine Ahorn Camp products and to have them installed at authorised service centres only. Any alteration to the vehicle and its systems (electrical, gas, water, etc.) not authorised in writing by Ahorn Camp involves the automatic invalidation of the guarantee.

The weight specifications and tests for motorhomes are uniformly regulated throughout the EU in EU Implementing Regulation No. 2021/535 (until June 2022: EU Implementing Regulation No. 1230/2012). We have summarised and explained the key terms and legal requirements from this regulation for you below. Our dealers and the Ahorn Camp configurator on our website offer you additional assistance in configuring your vehicle.

17.1 Technically permissible maximum laden mass

The technically permissible maximum laden mass of the vehicle (e.g. 3,500 kg) is a mass specification set by the manufacturer which the vehicle must not exceed. Information on the technically permissible maximum laden mass of the model you have chosen can be found in the technical data. If the vehicle exceeds the technically permissible maximum laden mass in everyday driving, this constitutes an administrative offence which may result in a fine.

17.2 Mass in running order

In simple terms, the mass in running order is the basic vehicle with standard equipment plus a legally fixed standard weight of 75 kg for the driver. This essentially includes the following items:

- the unladen weight of the vehicle together with the bodywork, including operating fluids such as greases, oils and coolants;
- the standard equipment, i.e. all equipment items that are included as standard in the factory-fitted scope of delivery;
- the fresh water tank filled to 100 % in driving mode (driving fill according to manufacturer's specifications; 20 litres) and an aluminium gas cylinder filled to 100 % with a weight of 16 kg;
- the fuel tank, which is 90 % full, including fuel;
- the driver, whose weight – regardless of the actual weight – is generally specified as 75 kg in accordance with EU law.

Information on the mass in running order can be found for each model in our sales documents. It is important to note that the value for mass in running order given in the sales documents is a default value determined in the type-approval procedure and verified by the authorities. It is legally permissible and possible for the mass in running order of the vehicle delivered to you to deviate from the nominal value stated in the sales documents. The legally permissible tolerance is $\pm 5\%$. In this way, the EU legislator accounts for the fact that certain fluctuations in the mass in running order occur due to variations in the weight of supplied parts as well as due to processes and weather conditions.

These weight deviations can be illustrated by means of an example calculation:

- Mass in running order acc. to sales documents: 2,850 kg
- Legally permissible tolerance of $\pm 5\%$: 142.50 kg
- Legally permissible range of mass in running order: 2,707.50 kg to 2,992.50 kg

The specific range of permissible weight deviations can be found for each model in the technical data. Ahorn Camp makes great efforts to reduce weight variations to the minimum that is unavoidable for production reasons. Deviations at the upper and lower end of the range are therefore very rare; however, they cannot be completely ruled out technically, even with all optimisations. The real weight of the vehicle and compliance with the permissible tolerance is therefore checked by Ahorn Camp by weighing each vehicle at the end of the line.

17.3 Mass of the passengers

The mass of the passengers is set a standard value of 75 kg for each seat provided by the manufacturer, regardless of the actual weight of the passengers. The mass of the driver is already included in the mass in running order (see paragraph 17.2) and is therefore not included again. In the case of a motorhome with four permitted seats, the mass of the passengers is therefore $3 * 75 \text{ kg} = 225 \text{ kg}$.

17.4 Optional equipment and actual mass of the vehicle

Optional equipment (also: additional equipment) includes, according to the legal definition, all optional equipment parts not included in the standard equipment which are fitted to the vehicle under the responsibility of the manufacturer – i.e. ex works – and can be ordered by the customer (e.g. awning, bicycle or motorbike carrier, satellite system, solar system, oven, etc.). Information on the individual or package weights of the optional equipment that can be ordered can be found in our sales documents. Optional equipment in this sense does not include other accessories that are retrofitted by the dealer or you personally after the vehicle has been delivered ex works.

The mass of the vehicle in running order (see paragraph 17.2) and the mass of the optional equipment fitted to a specific vehicle at the factory are together referred to as the actual mass. You will find the corresponding information for your vehicle after handover under item 13.2 of the Certificate of Conformity (CoC). Please note that this specification also represents a standardised value. Since the mass in running order – as an element of the actual mass – is subject to a legally permissible tolerance of $\pm 5\%$ (see paragraph 17.2), the actual mass may also deviate accordingly from the stated nominal value.

17.5 Pay-mass and minimum pay-mass

The installation of optional equipment is also subject to technical and legal limits: only so much optional equipment can be ordered and fitted at the factory that sufficient free weight remains for baggage and other accessories ("pay-mass") without exceeding the technically permissible maximum laden mass. The pay-mass is calculated by subtracting the mass in running order (nominal value according to sales documents, see paragraph 17.2), mass of the optional equipment (see paragraph 17.4) and the mass of the passengers (see paragraph 17.3) from the technically permissible maximum laden mass (see paragraph 17.1). The EU regulations stipulate a fixed minimum pay-mass for motorhomes, which must remain as a minimum for baggage or other non-factory-fitted accessories. This minimum pay-mass is calculated as follows:

Minimum pay-mass in kg $\geq 10 * (n + L)$

Where: "n" is the maximum number of passengers plus the driver and "L" is the overall length of the vehicle in metres.

For a motorhome with a length of 6 m and 4 approved seats, the minimum pay-mass is therefore e.g. $10 \text{ kg} * (4 + 6) = 100 \text{ kg}$.

To ensure that the minimum pay-mass is maintained, there is a maximum combination of optional equipment that can be ordered for each vehicle model. In the above example with a minimum pay-mass of 100 kg, the total mass of optional equipment for a vehicle with four permitted seats and a mass in running order of 2,850 kg should not exceed 325 kg:

3,500 kg technically permissible maximum laden mass

- 2,850 kg mass in running order

- 3 * 75 kg mass of the passengers

- 100 kg minimum pay-mass

= 325 kg maximum permissible mass of optional equipment

It is important to note that this calculation is based on the default value for mass in running order as defined in the type-approval procedure, without taking into account the permissible weight deviations for mass in running order (see paragraph 17.2). If the maximum permissible value for the optional equipment of (in the example) 325 kg is almost or completely exhausted, an upward weight deviation can therefore result in the minimum pay-mass of 100 kg being met mathematically using the default value for the mass in running order, although in fact there is no corresponding load capacity.

Here, too, an example calculation for a vehicle with four seats, whose real weighed mass in running order is 2 % above the nominal value:

3,500 kg technically permissible maximum laden mass

- 2,907 kg real weighed mass in running order (+ 2 % compared to the stated value of 2,850 kg)

- 3 * 75 kg mass of the passengers

- 325 kg optional equipment (maximum permissible value)

= 43 kg actual load capacity (< minimum pay-mass of 100 kg)

In order to avoid such a situation, Ahorn Camp further reduces the maximum permissible weight of the total optional equipment that can be ordered on a model-specific basis. The limitation of optional equipment is intended to ensure that the minimum pay-mass, i.e. the legally prescribed free mass for baggage and retrofitted accessories, is actually available for the vehicle load capacity of the vehicles delivered by Ahorn Camp.

Since the weight of a specific vehicle can only be determined when it is weighed at the end of the line, in very rare cases a situation may arise in which the minimum pay-mass at the end of the line is not guaranteed, despite this limitation of optional equipment. In order to guarantee the minimum pay-mass even in these cases, Ahorn Camp will check together with your trade partner and you before delivery of the vehicle whether, for example, the vehicle is loaded up, seats are reduced or optional equipment is removed.

17.6 Effects of tolerances of the mass in running order on the pay-mass

Regardless of the minimum pay-mass, you should note that unavoidable production-related fluctuations in the mass in running order – both upwards and downwards – have a mirror-image effect on the remaining load capacity: if you order our example vehicle (see paragraph 17.5), for example, with optional equipment with a total weight of 150 kg, the calculated pay-mass based on the default value for the mass in running order is 275 kg. The load capacity actually available may deviate from this value due to tolerances and may be higher or lower. If the mass in running order of your vehicle is, for example, permissibly 2 % higher than stated in the sales documents, the load capacity is reduced from 275 kg to 218 kg:

3.500 kg technically permissible maximum laden mass

- 2.907 kg real weighed mass in running order (+ 2 % compared to the stated value of 2,850 kg)

- 3 * 75 kg mass of the passengers

- 150 kg optional equipment ordered for the specific vehicle

= 218 kg actual load capacity

As a precaution to ensure that the calculated pay-mass is actually given, you should therefore take the possible and permissible tolerances for the mass in running order into account when configuring your vehicle.

We also recommend that you weigh the laden motorhome on a non-automatic scale before each journey and, taking the individual weight of the passengers into account, determine whether the technically permissible maximum laden mass and the technically permissible maximum mass on the axle are observed.

The technical data and specifications contained herein refer to Ahorn Camp vehicles manufactured when this handbook was printed. Pursuing an attentive policy of continuous product improvement, Ahorn Camp reserves the right to change these data at any time without prior notice and declining any form of liability whatsoever.

© Ahorn Camp

No part of this handbook may be reproduced without prior consent of Ahorn Camp.